

**RULON PANEL GRILLE SUSPENDED WOOD CEILING SYSTEM**  
**ARCHITECTURAL SPECIFICATIONS**

**PART 1 - GENERAL**

- A. The Panel Grille Suspended Wood Ceiling Systems covered by this specification shall be the products of the Rulon International, World Commerce Center, 2000 Ring Way Road, St. Augustine, FL 32092. Phone: 800-227-8566, Fax: 904-584-1499.
- B. The General Conditions and the requirements of Division 1 of the specifications shall apply to all work hereunder.
- C. All work shall be performed in accordance with the manufacturer's instructions, and in a manner satisfactory to the owner's representative.

**1.01 SCOPE**

Rulon International shall furnish all Panel Grilles and suspension [dowel or woodbacker] clips necessary to complete installation by the contractor, in accordance with plans and specifications. The standard heavy-duty 15/16" T-rail carriers shall be supplied by contractor.

**1.02 RELATED WORK NOT INCLUDED UNDER THIS SECTION**

Suspension systems and components for ceilings, other than manufacturer's Panel Grille Suspended Wood Ceiling System, are not included.

**1.03 QUALITY ASSURANCE**

- A. **Installer Qualifications:** The installer must be a firm with a minimum of two (2) years of successful experience in installation of suspended wood ceilings of similar requirements to this project. The installer must be acceptable to the architect, manufacturer, and owner's representative.
- B. **Fire Performance Characteristics:** When specified as "Fire Resistant", Panel Grille wood strips shall conform to Class 1, or A flame spread rating, when tested according to ASTM E-84.
- C. **Environmental Standards:** When required the wood ceiling shall originate from well managed forests as certified by accredited and recognized industry certifying organizations.

#### **1.04 PROJECT CONDITIONS**

Installation shall be done only when the temperature and humidity closely approximate the interior conditions that will exist when the building is occupied. The heating and cooling systems shall be operating before, during, and after installation, with the humidity of the interior spaces maintained between 25% and 55%.

It is important that plenums have proper ventilation, especially in high moisture areas. There shall be no excessive build up of heat in the ceiling areas.

Prior to the start of installation, all exterior windows and doors are to be in place, glazed, and weather-stripped. The roof is to be watertight, and all wet trades' work is to be completed, and thoroughly dry.

Mechanical, electrical, and other utility service installations above the ceiling plane shall have been completed. No materials should rest against, or wrap around, the ceiling suspension components or connecting hangers.

#### **1.05 COORDINATION OF WORK**

The layout and installation of Panel Grilles and ceiling suspension system shall be coordinated with other work penetrating the ceiling. This includes light fixtures, HVAC equipment, and fire suppression system components.

#### **1.06 SUBMITTALS**

- A. Product Data: Rulon International shall provide product specifications and installation instructions for all supplied ceiling materials.
- B. Shop Drawings: When required, Rulon International shall supply shop drawings showing Panel Grille lengths, and placement of hangers, T-rail carriers, and other details deemed pertinent to proper installation.
- C. Samples: A 12"x12" inch wood ceiling sample, in the specified Panel Grille style, with finish applied, shall be submitted for approval.

#### **1.07 DELIVERY, STORAGE, AND HANDLING**

- A. Panel Grilles and components shall be delivered to the project site in original, unopened packages.
- B. The Panel Grilles shall be stored flat and level in a fully enclosed space. For a minimum of seventy-two (72) hours immediately prior to ceiling installation, the Panel Grilles shall be stored in the room in which they will be installed. The temperature and humidity of the room shall closely approximate those conditions that will exist when the building is occupied. The Panel Grilles must be stored off the floor.
- C. Care in handling must be exercised to avoid damage.

## 1.08 WARRANTIES

- A. Manufacturer: All materials supplied by the ceiling manufacturer shall be guaranteed against manufacturing defects for one (1) year. Because of differing site conditions, wood stains and colorings can vary with age, and are excluded from this warranty.
- B. Contractor: All work shall be guaranteed for one (1) year from final acceptance of completed work.

## PART 2 - PRODUCT

### 2.01 PANEL GRILLES

The wood strips shall be manufactured by Rulon International, St. Augustine, Florida, PH-1-800-227-8566. The wood strips shall be made from prime grade, all-natural [specie] with a [selected] finish. The Panel Grille shall be [pattern number] having wood strips [X] inches wide x [X] inches deep with [X] inches spacing between strips.

Standard Panel Grilles shall be assembled 1' wide - in nominal lengths of 2' to 10' in 1' increments (actual lengths are 1" shorter to allow for a reveal between panels; i.e., an 8' panel is 7'-11"). Wood strips shall be manufactured without finger-joints, and fastened together with black dowels [and/or woodbackers, depending on panel design]. The dowels [and/or woodbackers] shall be positioned 5-1/2" from the ends and 12" on center, with interconnecting male-to-female dowel attachment [and/or with overlapping woodbackers, depending on panel design] for support of the system.

Wood is a natural product that will undergo changes with variations in the environment. Therefore, all dimension tolerances are  $\pm 1/8"$ .

### 2.02 SUSPENSION SYSTEMS

Panel Grilles shall be suspended from standard heavy-duty 15/16" T-rail carriers (supplied by contractor) - using Rulon [dowel or woodbacker] clips for connection when removability of panel grilles is necessary for access above the ceiling. #12 gauge wire hangers shall suspend T-rail carriers.

### 2.03 EDGES, BORDERS, AND PERIMETER TRIMS

Edges, borders, and perimeter trims, shall be designated by specifier in accordance with standard design details available. All wood ceiling products specified shall be supplied by the ceiling manufacturer.

## 2.04 FINISHES AND COLORS

All Panel Grilles shall be factory-finished with clear sealers, wood stains, or semi-transparent color treatments as selected. All finishes shall be selected by the designer, architect, or designated owner's representative.

Wood is a natural product with variations in grain, texture, and color - often ranging from light to dark - thereby, affecting the surface look. Product finishes shall be stain or sealer coats, spray-applied to a smooth-sanded surface.

## PART 3 - EXECUTION

### 3.01 PREPARATION

- A. Ceiling Layout: The contractor shall measure ceiling areas, and establish layout of Panel Grilles and T-rails, in accordance with installation instructions.
- B. Coordination: The contractor shall furnish the layout for supports that shall be installed for suspension of ceilings. He shall furnish concrete inserts, steel deck hanger clips, or similar devices for installation, in time to coordinate the work. The contractor shall coordinate with other trades the location of devices which will penetrate the Ceiling Panels or interfere with the installation. Recessed or surface devices located within the ceiling panels are to be located and cut in the field.

### 3.02 INSTALLATION

- A. General: The contractor shall install materials in accordance with Rulon International printed instructions. The installation shall comply with applicable regulations and industry standards.
- B. Perimeters: Using a leveling device, the contractor shall lay out and install the perimeter trim as specified.
- C. Suspension: The T-rail carriers shall be suspended and leveled in a direction perpendicular to the wooden strip direction. #12 gauge wire hangers shall be used to support T-rail carriers. Hangers shall be placed at 4' intervals along the carrier.
- D. Wood Suspension: Panel Grilles shall be suspended from the T-rail carrier system by [dowel or woodbacker] clips.

### 3.03 ADJUSTMENT, CLEANING, AND REPAIR

- A. The contractor shall make final adjustments to level or contours.
- B. Upon completion of ceiling installation, all Panel Grilles and borders shall be cleaned free of dirt, dust, grease, oils, and fingerprints.

- C. All work which cannot be successfully cleaned or repaired, shall be removed and replaced.

### **3.04 INSPECTION**

Upon completion of ceiling installation, the owner's representative shall inspect all finished surfaces to ensure that work has been performed in a manner satisfactory to the owner. Any deficiencies in the installed ceiling shall be corrected by the contractor at no additional cost to the owner, or to the ceiling manufacturer.

**RULON PANEL GRILLE WOOD WALL SYSTEM**  
**ARCHITECTURAL SPECIFICATIONS**

**PART 1 - GENERAL**

- A. The Panel Grille Wood Wall Systems covered by this specification shall be the products of the Rulon International, World Commerce Center, 2000 Ring Way Road, St. Augustine, FL 32092. Phone: 800-227-8566, Fax: 904-584-1499.
- B. The General Conditions and the requirements of Division 1 of the specifications shall apply to all work hereunder.
- C. All work shall be performed in accordance with the manufacturer's instructions, and in a manner satisfactory to the owner's representative.

**1.01 SCOPE**

Rulon International shall furnish all Panel Grilles and wood trim necessary to complete installation by the contractor, in accordance with plans and specifications.

**1.02 RELATED WORK NOT INCLUDED UNDER THIS SECTION**

Components for walls, other than manufacturer's Panel Grille Wood Wall System, are not included.

**1.03 QUALITY ASSURANCE**

- A. **Installer Qualifications:** The installer must be a firm with a minimum of two (2) years of successful experience in installation of wood walls of similar requirements to this project. The installer must be acceptable to the architect, manufacturer, and owner's representative.
- B. **Fire Performance Characteristics:** When specified as "Fire Resistant", Panel Grille wood strips shall conform to Class 1, or A flame spread rating, when tested according to ASTM E-84.
- C. **Environmental Standards:** When required the wood wall shall originate from well managed forests as certified by accredited and recognized industry certifying organizations.

#### **1.04 PROJECT CONDITIONS**

Installation shall be done only when the temperature and humidity closely approximate the interior conditions that will exist when the building is occupied. The heating and cooling systems shall be operating before, during, and after installation; with the humidity of the interior spaces maintained between 25% and 55%.

It is important that plenums have proper ventilation, especially in high moisture areas. There shall be no excessive build up of heat in the wall areas.

Prior to the start of installation, all exterior windows and doors are to be in place, glazed, and weather-stripped. The roof is to be watertight, and all wet trades' work is to be completed, and thoroughly dry.

Mechanical, electrical, and other utility service installations beyond the wall plane shall have been completed. No materials should rest against, or wrap around, the wall attachment components or connecting hangers.

#### **1.05 COORDINATION OF WORK**

The layout and installation of Panel Grilles shall be coordinated with other work penetrating the wall.

#### **1.06 SUBMITTALS**

- A. Product Data: Rulon International shall provide product specifications and installation instructions for all supplied wall materials.
- B. Shop Drawings: When required, Rulon International shall supply shop drawings showing Panel Grille lengths and placement, and any other details necessary for proper installation.
- C. Samples: A 12"x12" wood wall sample, in the specified Panel Grille style, with finish applied, shall be submitted for approval.

#### **1.07 DELIVERY, STORAGE, AND HANDLING**

- A. Panel Grilles and components shall be delivered to the project site in original, unopened packages.
- B. The Panel Grilles shall be stored flat and level in a fully enclosed space. For a minimum of seventy-two (72) hours immediately prior to installation, the Panel Grilles shall be stored in the room in which they will be installed. The temperature and humidity of the room shall closely approximate those conditions that will exist when the building is occupied. The Panel Grilles must be stored off the floor.
- C. Care in handling must be exercised to avoid damage.

## 1.08 WARRANTIES

- A. Manufacturer: All materials supplied by the Panel Grille manufacturer shall be guaranteed against manufacturing defects for one (1) year. Because of differing site conditions, wood stains and colorings can vary with age, and are excluded from this warranty.
- B. Contractor: All work shall be guaranteed for one (1) year from final acceptance of completed work.

## PART 2 - PRODUCT

### 2.01 PANEL GRILLES

The wood strips shall be manufactured by Rulon International, St. Augustine, Florida, PH-1-800-227-8566. The wood strips shall be made from prime grade, all-natural [specie] with a [selected] finish. The Panel Grille shall be [pattern number] having wood strips [X] inches wide x [X] inches deep with [X] inches spacing between strips.

Standard Panel Grilles shall be assembled 1' wide - in nominal lengths of 2' to 10' in 1' increments (actual lengths are 1" shorter to allow for a reveal between panels; i.e., an 8' panel is 7'-11"). Wood strips shall be manufactured without finger-joints, and fastened together with black dowels and woodbackers. The dowels and woodbackers shall be positioned 5-1/2" from the ends and 12" on center, with interconnecting male-to-female dowel attachment for support of the system.

Wood is a natural product that will undergo changes with variations in the environment. Therefore, all dimension tolerances are  $\pm 1/8"$ .

### 2.02 SUPPORT SYSTEMS

Panel Grilles shall be attached to a framing system, not provided by Rulon, in accordance with current architectural drawings.

### 2.03 EDGES, BORDERS, AND PERIMETER TRIMS

Edges, borders, and perimeter trims, shall be designated by specifier in accordance with standard design details available. All wood wall products specified shall be supplied by the panel grille manufacturer.

### 2.04 FINISHES AND COLORS

All Panel Grilles shall be factory-finished with clear sealers, wood stains, or semi-transparent color treatments as selected. All finishes shall be selected by the designer, architect, or designated owner's representative.

Wood is a natural product with variations in grain, texture, and color - often ranging from light to dark - thereby, affecting the surface look. Product finishes shall be stain or sealer coats, spray-applied to a smooth-sanded surface.

### **PART 3 - EXECUTION**

#### **3.01 PREPARATION**

- A. Layout: The contractor shall measure wall areas, and establish layout of Panel Grilles and support framing, in accordance with installation instructions.
- B. Coordination: The contractor shall furnish the layout for supports that shall be installed for attachment of the panel grilles.

#### **3.02 INSTALLATION**

- A. General: The contractor shall install materials in accordance with Rulon International printed instructions. The installation shall comply with applicable regulations and industry standards.
- B. Attachment: Panel Grilles shall be attached to the framing system. Woodbacked Panel Grilles shall be attached by screwing or nailing through the woodbacker into contractor-installed wall furring. If panels are not woodbacked, the wood strips on both sides of the interconnecting male-to-female dowel connection are to be attached to the framing members.
- C. Perimeters: The Panel Grilles shall be manufactured to allow for a standard 1" reveal between Panel Grille bays.

#### **3.03 ADJUSTMENT, CLEANING, AND REPAIR**

- A. The contractor shall make final adjustments to level or contours.
- B. Upon completion of wall installation, all Panel Grilles and borders shall be cleaned free of dirt, dust, grease, oils, and fingerprints.
- C. All work which cannot be successfully cleaned or repaired, shall be removed and replaced.

#### **3.04 INSPECTION**

Upon completion of Wall installation, the owner's representative shall inspect all finished surfaces to ensure that work has been performed in a manner satisfactory to the owner. Any deficiencies in the installed Wall shall be corrected by the contractor at no additional cost to the owner, or to the Wall manufacturer.

<u>DRAWING #</u>	<u>TITLE</u>	<u>DRAWING #</u>	<u>TITLE</u>
CEILING DETAILS		GDCXX016	Panel Grille Miter Joint Detail
GDCXX001	Panel Grille - Doweled - Perimeter Detail - Side	GDCXX017	Panel Grille - Flexible Doweled - Grid Radius Detail
GDCXX002	Panel Grille - Doweled - Perimeter Detail - End	GDCXX018	Panel Grille - Doweled - End Cap and Junction Trim Detail
GDCXX003	Panel Grille - Doweled - Panel to Panel Reveal Detail	GDCXX019	Panel Grille - Doweled - Panel Removal Detail
GDCXX004	Panel Grille - Dowel Clip Detail	GDCXX024	Panel Grille - Doweled - Strip Light Installation Detail
GDCXX005	Panel Grille - Dowel Clip Placement Detail		
GDCXX006	Panel Grille - Doweled - Can Light Detail		
GDCXX007	Panel Grille - Doweled - Sprinkler Detail		
GXXXX008	Typical Panel Grille Assembly	WALL MOUNT DETAIL	
GXXXX009	Panel Grille Trimming Detail	GBWXX031	Panel Grille - Doweled Woodbacked - Wall Mount Detail
GDCXX011	Panel Grille - Doweled - Seismic Detail		
GWCXX012	Panel Grille - Direct Attachment to Woodbacker Detail		
GDCXX013	Panel Grille - Doweled - Direct Ceiling Mount Detail		

 <p><b>RULON INTERNATIONAL</b></p>	<p>World Commerce Center 2000 Ring Way Road St. Augustine, FL 32092 Ph: 1-800-227-8566 904-584-1400 Fax: 904-584-1499 www.rulonco.com info@rulonco.com</p>	PROJECT:	ISSUE DATE:	DRAWN BY:	PROJECT NUMBER:
		TITLE: <b>Panel Grille Ceiling and Wall Index</b>	REVISION DATE: <b>MAY/11/2011</b>	CAP	CHECKED BY: <b>TA</b>

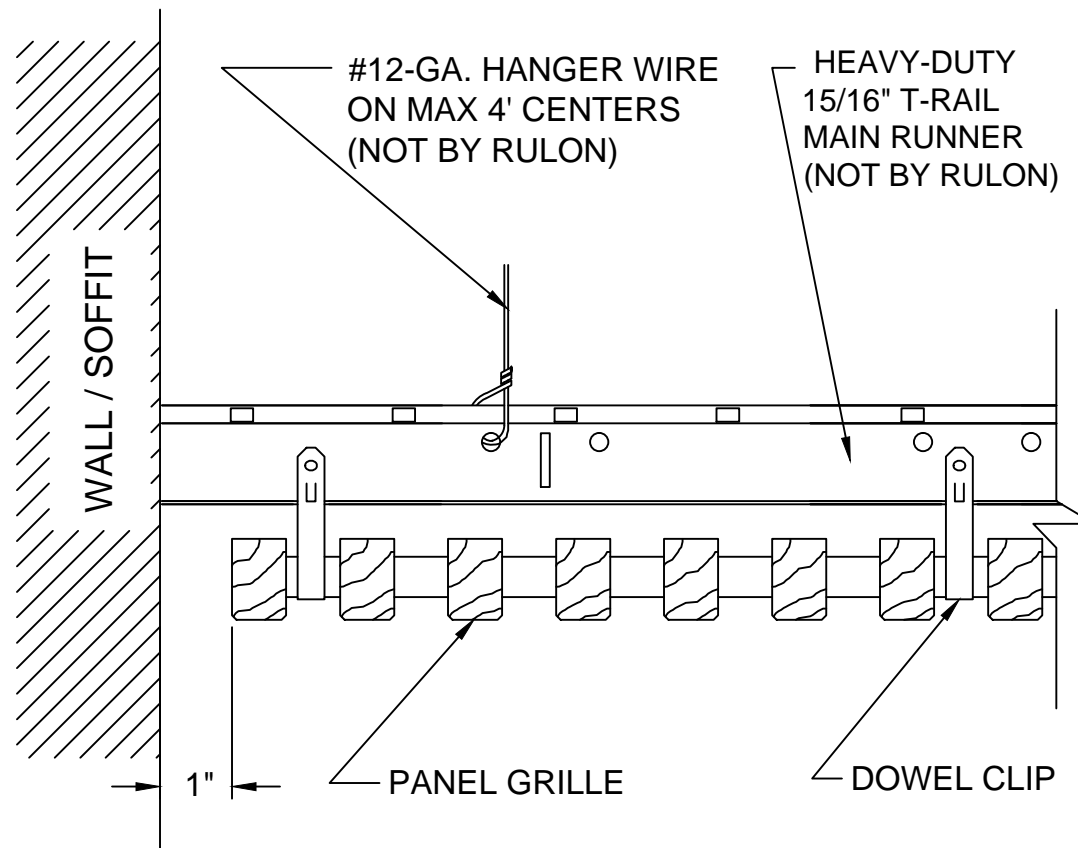

RULON INTERNATIONAL

World Commerce Center  
 2000 Ring Way Road  
 St. Augustine, FL 32092  
 Ph: 1-800-227-8566  
 904-584-1400  
 Fax: 904-584-1499  
 www.rulonco.com  
 info@rulonco.com

PROJECT:

TITLE:

Panel Grille - Doweled - Perimeter  
 Detail - Side

ISSUE DATE:

REVISION DATE:

MAY/11/2011

DRAWN BY:

CAP

CHECKED BY:

TA

PROJECT NUMBER:

DRAWING NUMBER:

GDCXX001

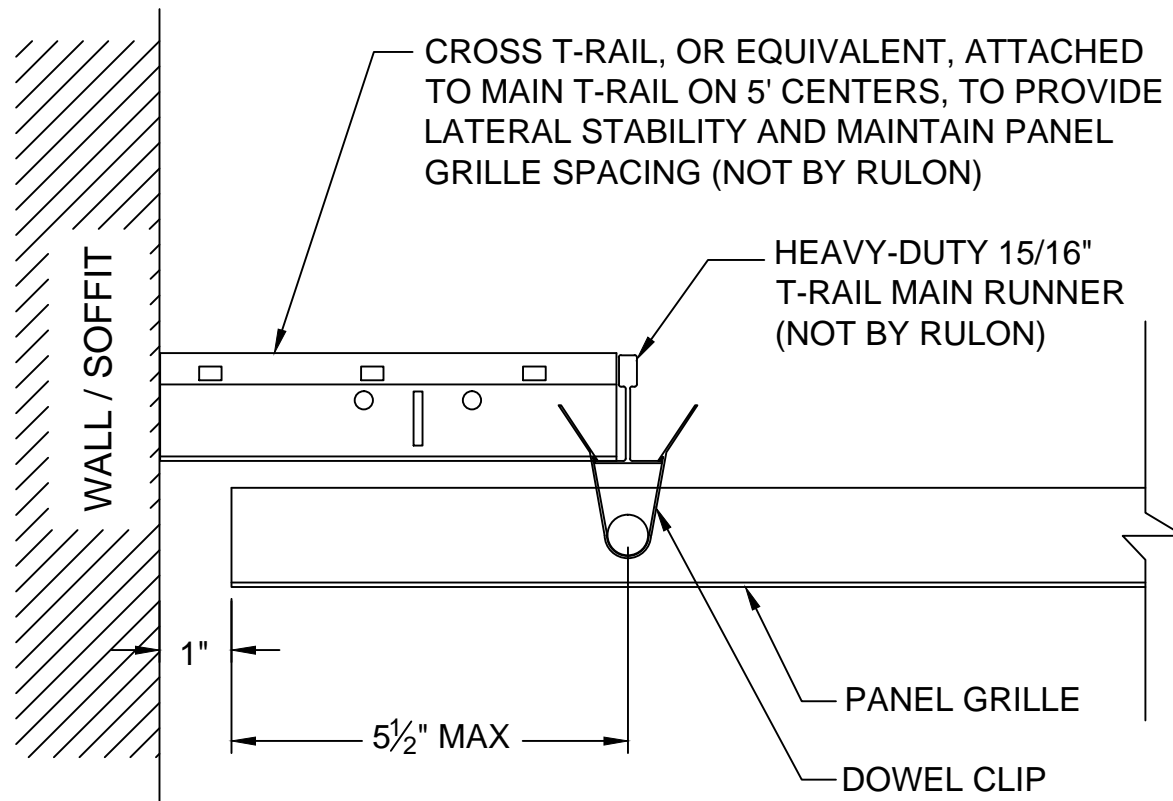

RULON INTERNATIONAL

World Commerce Center  
 2000 Ring Way Road  
 St. Augustine, FL 32092  
 Ph: 1-800-227-8566  
 904-584-1400  
 Fax: 904-584-1499  
 www.rulonco.com  
 info@rulonco.com

PROJECT:

TITLE:

Panel Grille - Doweled - Perimeter  
 Detail - End

ISSUE DATE:

REVISION DATE:

MAY/11/2011

DRAWN BY:

CAP

CHECKED BY:

TA

PROJECT NUMBER:

DRAWING NUMBER:

GDCXX002

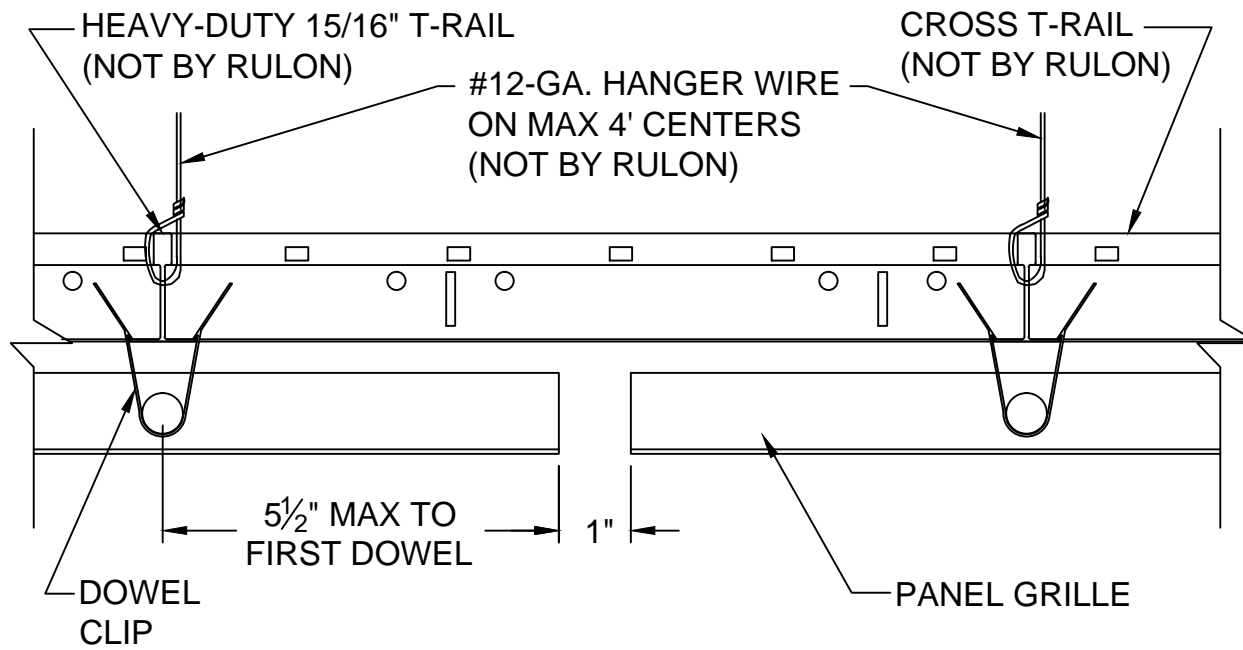

RULON INTERNATIONAL

World Commerce Center  
2000 Ring Way Road  
St. Augustine, FL 32092  
Ph: 1-800-227-8566  
904-584-1400  
Fax: 904-584-1499  
www.rulonco.com  
info@rulonco.com

PROJECT:

TITLE:

Panel Grille - Doweled - Panel to  
Panel Reveal Detail

ISSUE DATE:

REVISION DATE:

MAY/11/2011

DRAWN BY:

CAP

CHECKED BY:

TA

PROJECT NUMBER:

DRAWING NUMBER:

GDCXX003

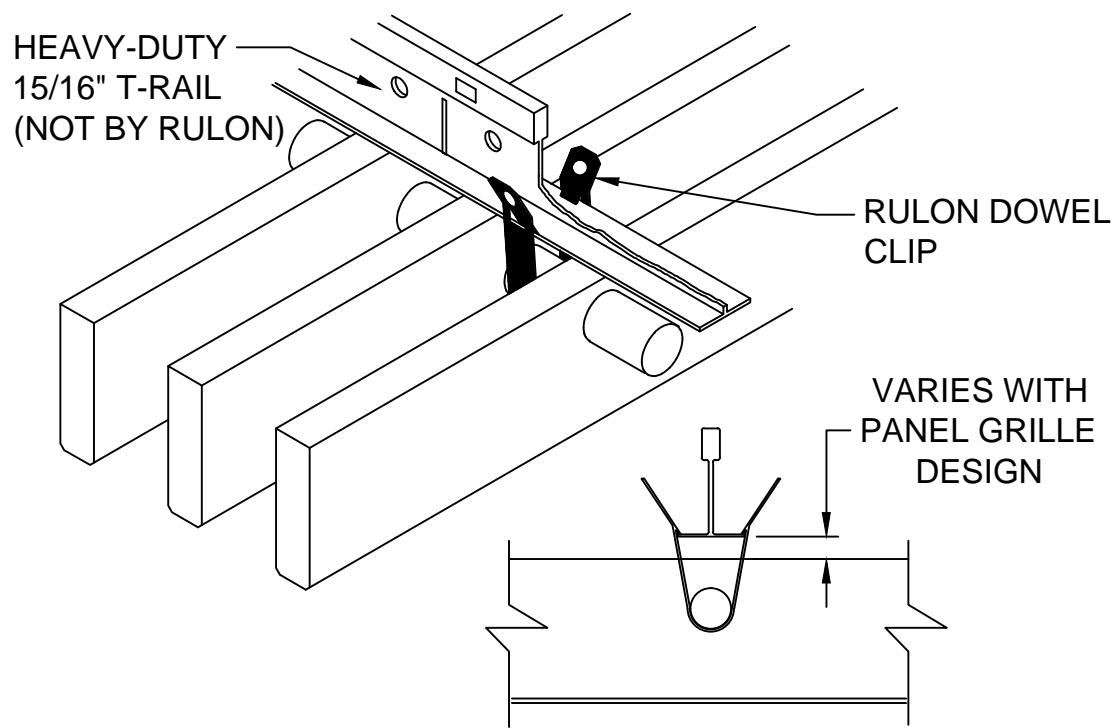

**RULON INTERNATIONAL**

World Commerce Center  
2000 Ring Way Road  
St. Augustine, FL 32092  
Ph: 1-800-227-8566  
904-584-1400  
Fax: 904-584-1499  
www.rulonco.com  
info@rulonco.com

PROJECT:

TITLE:

**Panel Grille - Dowel Clip Detail**

ISSUE DATE:

REVISION DATE:

**MAY/11/2011**

DRAWN BY:

**CAP**

CHECKED BY:

**TA**

PROJECT NUMBER:

DRAWING NUMBER:

**GDCXX004**

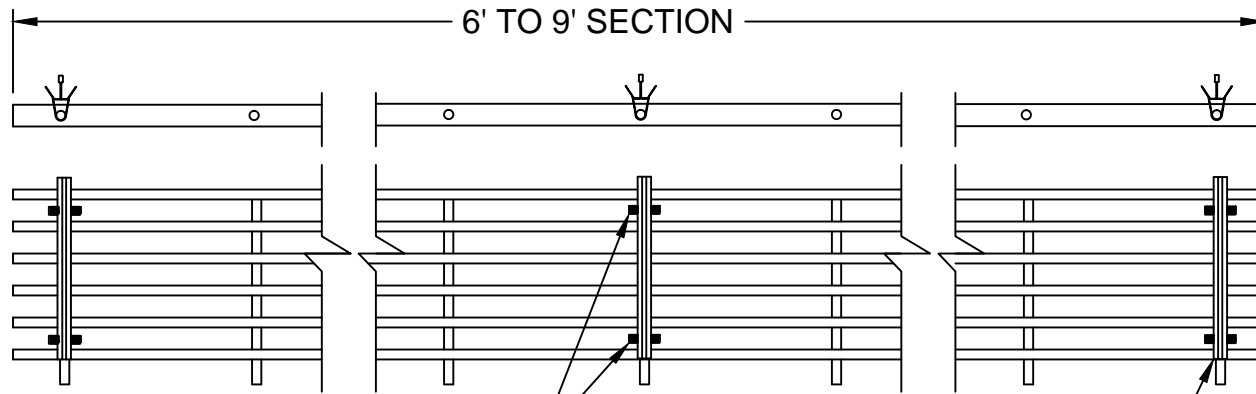

2 CLIPS PLACED AS CLOSE TO  
PANEL GRILLE CENTER AS  
POSSIBLE

6 CLIPS NEEDED  
PER PANEL GRILLE

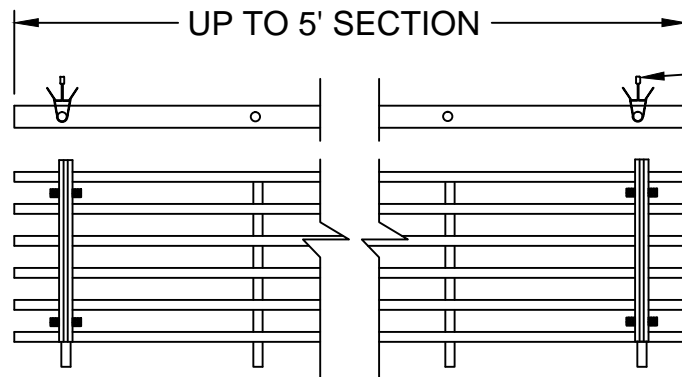

4 CLIPS NEEDED  
PER PANEL GRILLE

CLIP ATTACHED TO  
HEAVY-DUTY 15/16" T-GRID  
FOR PANELS GREATER THAN 9'  
LONG, CLIPS SHOULD NEVER BE  
MORE THAN 4' APART

**NOTES:**

1. PANEL GRILLES WIDER THAN 1' REQUIRE ADDITIONAL CLIPS TO MAINTAIN A LEVEL PLANE
2. FLEXIBLE PANEL GRILLES REQUIRE ADDITIONAL CLIPS TO MAINTAIN RADIUS



**RULON INTERNATIONAL**

World Commerce Center  
2000 Ring Way Road  
St. Augustine, FL 32092  
Ph: 1-800-227-8566  
904-584-1400  
Fax: 904-584-1499  
www.rulonco.com  
info@rulonco.com

PROJECT:

TITLE: **Panel Grille - Dowel Clip  
Placement Detail**

ISSUE DATE:

REVISION DATE:

**MAY/11/2011**

DRAWN BY:

**CAP**

CHECKED BY:

**TA**

PROJECT NUMBER:

DRAWING NUMBER:

**GDCXX005**

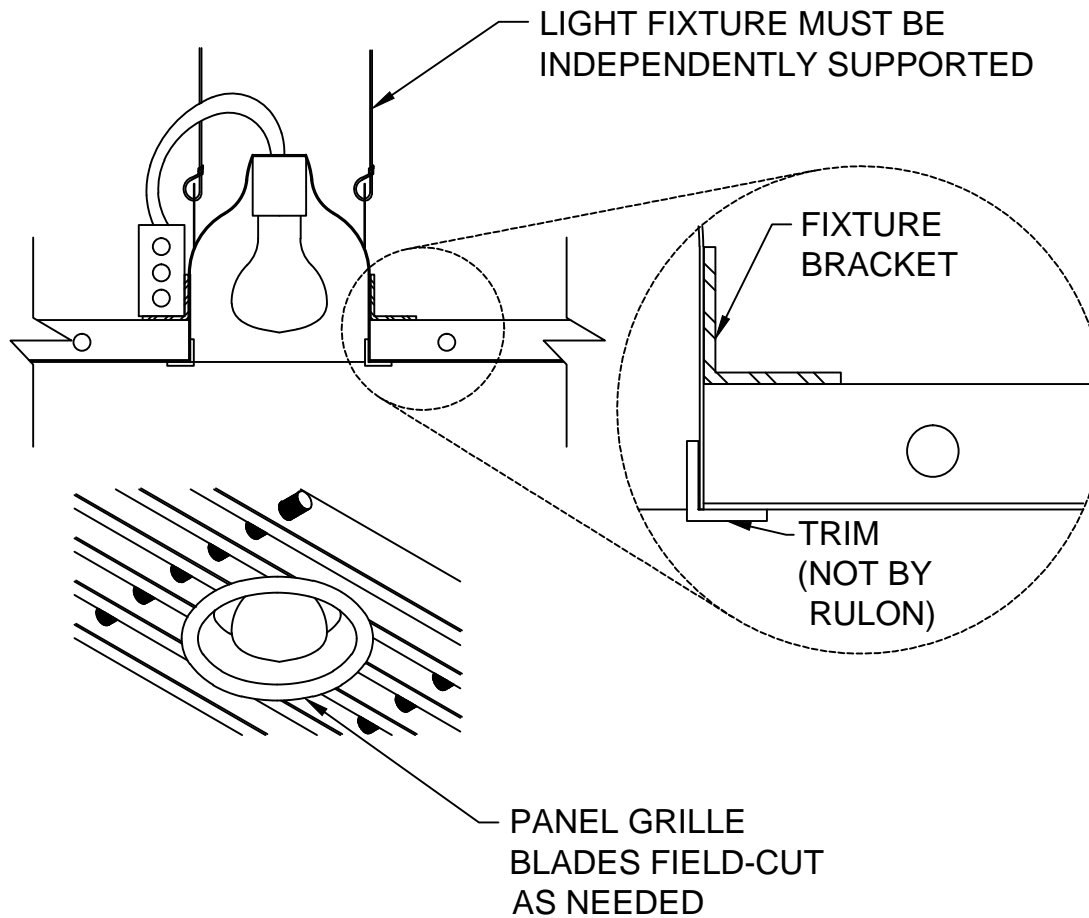

**RULON INTERNATIONAL**

World Commerce Center  
 2000 Ring Way Road  
 St. Augustine, FL 32092  
 Ph: 1-800-227-8566  
 904-584-1400  
 Fax: 904-584-1499  
 www.rulonco.com  
 info@rulonco.com

PROJECT:

TITLE:

**Panel Grille - Doweled - Can Light  
 Detail**

ISSUE DATE:

REVISION DATE:

**MAY/11/2011**

DRAWN BY:

**CAP**

CHECKED BY:

**TA**

PROJECT NUMBER:

DRAWING NUMBER:

**GDCXX006**

HEAVY-DUTY 15/16" T-RAIL  
(NOT BY RULON)

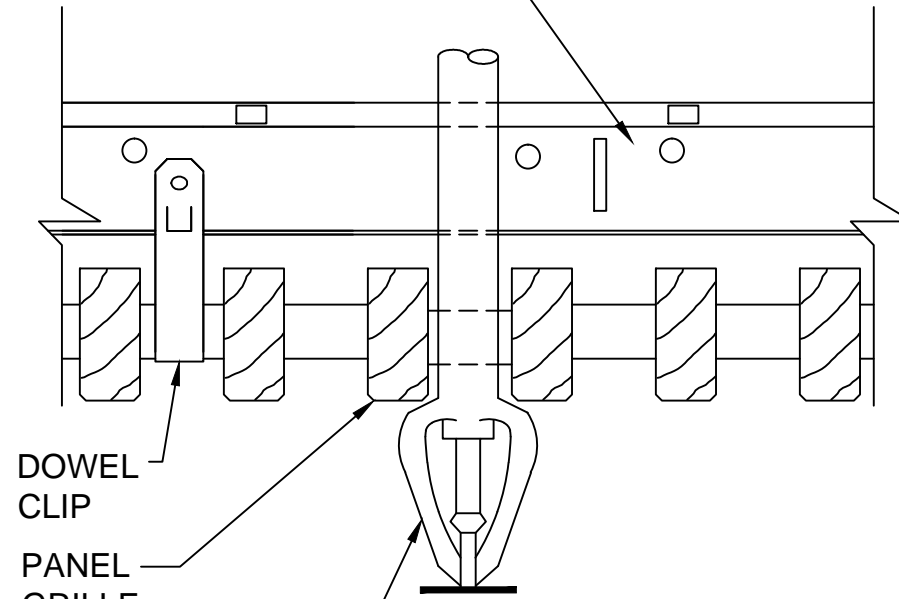

DOWEL  
CLIP

PANEL  
GRILLE

SPRINKLER HEAD  
(NOT BY RULON)



**RULON INTERNATIONAL**

World Commerce Center  
2000 Ring Way Road  
St. Augustine, FL 32092  
Ph: 1-800-227-8566  
904-584-1400  
Fax: 904-584-1499  
www.rulonco.com  
info@rulonco.com

PROJECT:

TITLE:

**Panel Grille - Doweled - Sprinkler  
Detail**

ISSUE DATE:

REVISION DATE:

**MAY/11/2011**

DRAWN BY:

**CAP**

CHECKED BY:

**TA**

PROJECT NUMBER:

DRAWING NUMBER:

**GDCXX007**

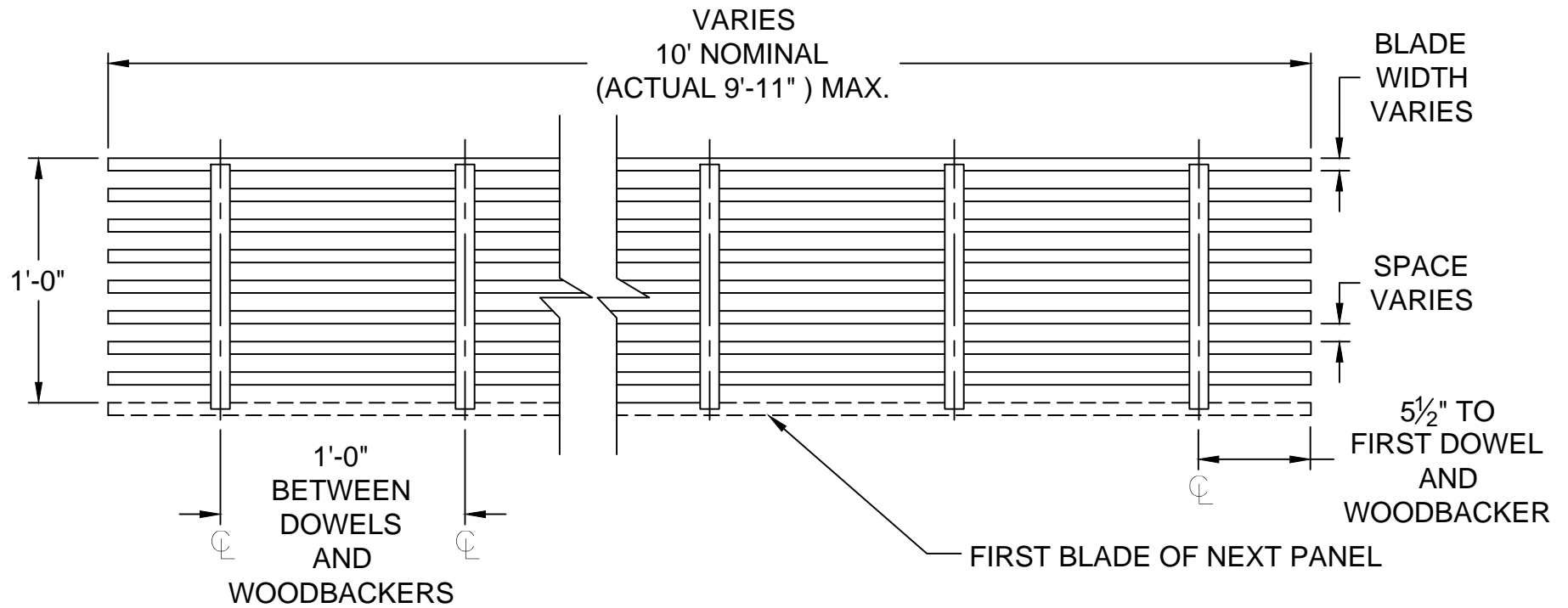

PANEL GRILLE WOOD BLADES VARY IN  
WIDTH, DEPTH, AND SPACING BETWEEN  
BLADES, DEPENDING ON STYLE CHOSEN



**RULON INTERNATIONAL**

World Commerce Center  
2000 Ring Way Road  
St. Augustine, FL 32092  
Ph: 1-800-227-8566  
904-584-1400  
Fax: 904-584-1499  
www.rulonco.com  
info@rulonco.com

PROJECT:

TITLE: Typical Panel Grille Assembly

ISSUE DATE:

REVISION DATE:

MAY/11/2011

DRAWN BY:

CAP

CHECKED BY:

TA

PROJECT NUMBER:

DRAWING NUMBER:

GXXXX008

ATTACH WOOD STRIP OR  
SHORT PIECE OF T-RAIL  
TO BACK OF PANEL WITH  
WOOD SCREWS BEFORE  
CUTTING.

TRIM LINE -  
TOUCH-UP ALL  
FIELD-CUT  
ENDS WITH  
SUPPLIED  
TOUCH-UP  
FINISH

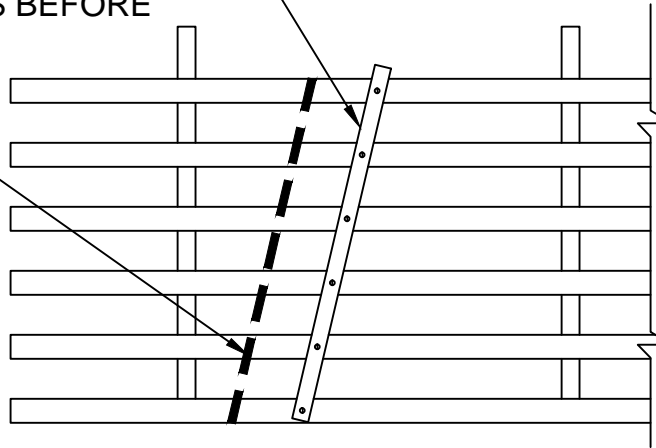

NOTE:  
WHEN CUTTING PANEL GRILLES, BLADES SHOULD  
NOT EXTEND BEYOND 6" UNSUPPORTED



**RULON INTERNATIONAL**

World Commerce Center  
2000 Ring Way Road  
St. Augustine, FL 32092  
Ph: 1-800-227-8566  
904-584-1400  
Fax: 904-584-1499  
www.rulonco.com  
info@rulonco.com

PROJECT:

TITLE:

**Panel Grille Trimming Detail**

ISSUE DATE:

REVISION DATE:

**MAY/11/2011**

DRAWN BY:

**CAP**

CHECKED BY:

**TA**

PROJECT NUMBER:

DRAWING NUMBER:

**GXXXX009**

WRAP WIRE THROUGH  
DOWEL CLIP HOLES AND  
LOOP AROUND T-RAIL

HEAVY-DUTY  
15/16" T-RAIL  
(NOT BY RULON)

RULON  
DOWEL  
CLIP

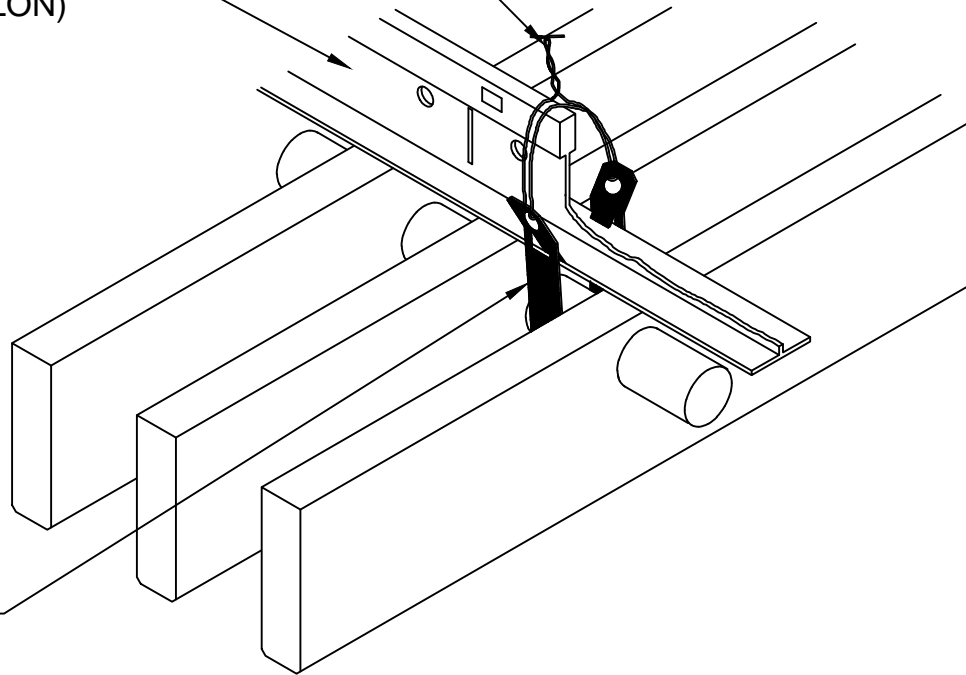

RULON INTERNATIONAL

World Commerce Center  
2000 Ring Way Road  
St. Augustine, FL 32092  
Ph: 1-800-227-8566  
904-584-1400  
Fax: 904-584-1499  
www.rulonco.com  
info@rulonco.com

PROJECT:

TITLE:

Panel Grille - Doweled - Seismic  
Detail

ISSUE DATE:

REVISION DATE:

MAY/11/2011

DRAWN BY:

CAP

CHECKED BY:

TA

PROJECT NUMBER:

DRAWING NUMBER:

GDCXX011

HEAVY-DUTY  
15/16" T-RAIL  
(NOT BY RULON)

DIRECT ATTACHMENT  
WITH WOOD SCREW  
(NOT BY RULON)

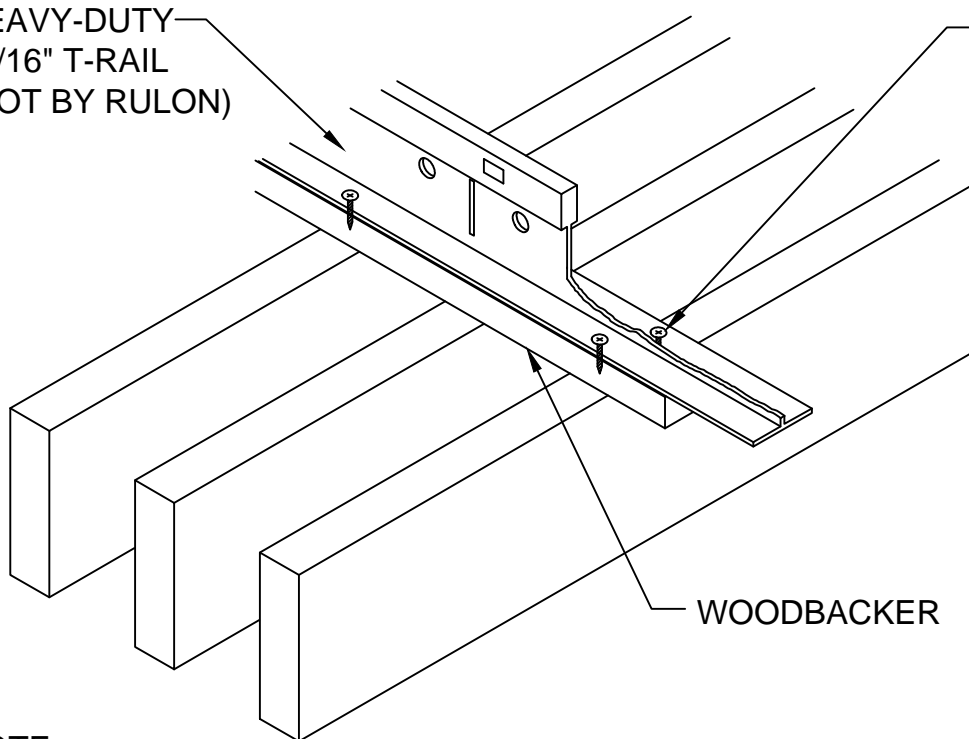

WOODBACKER

NOTE  
USE ADEQUATE SCREWS TO  
HOLD WEIGHT OF PANEL GRILLE  
(WILL VARY DEPENDING ON STYLE)



RULON INTERNATIONAL

World Commerce Center  
2000 Ring Way Road  
St. Augustine, FL 32092  
Ph: 1-800-227-8566  
904-584-1400  
Fax: 904-584-1499  
www.rulonco.com  
info@rulonco.com

PROJECT:

TITLE:

Panel Grille - Direct Attachment to  
Woodbacker Detail

ISSUE DATE:

REVISION DATE:

MAY/11/2011

DRAWN BY:

CAP

CHECKED BY:

TA

PROJECT NUMBER:

DRAWING NUMBER:

GWCXX012

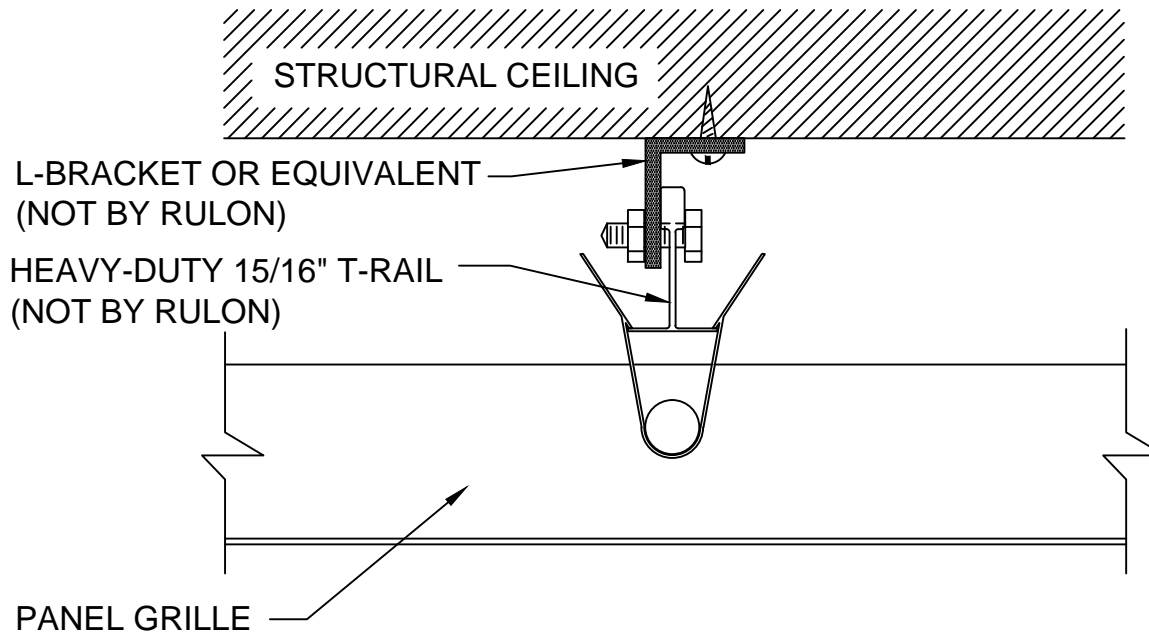

**RULON INTERNATIONAL**

World Commerce Center  
2000 Ring Way Road  
St. Augustine, FL 32092  
Ph: 1-800-227-8566  
904-584-1400  
Fax: 904-584-1499  
www.rulonco.com  
info@rulonco.com

PROJECT:

TITLE:

**Panel Grille - Doweled - Direct  
Ceiling Mount Detail**

ISSUE DATE:

REVISION DATE:

**MAY/11/2011**

DRAWN BY:

**CAP**

CHECKED BY:

**TA**

PROJECT NUMBER:

DRAWING NUMBER:

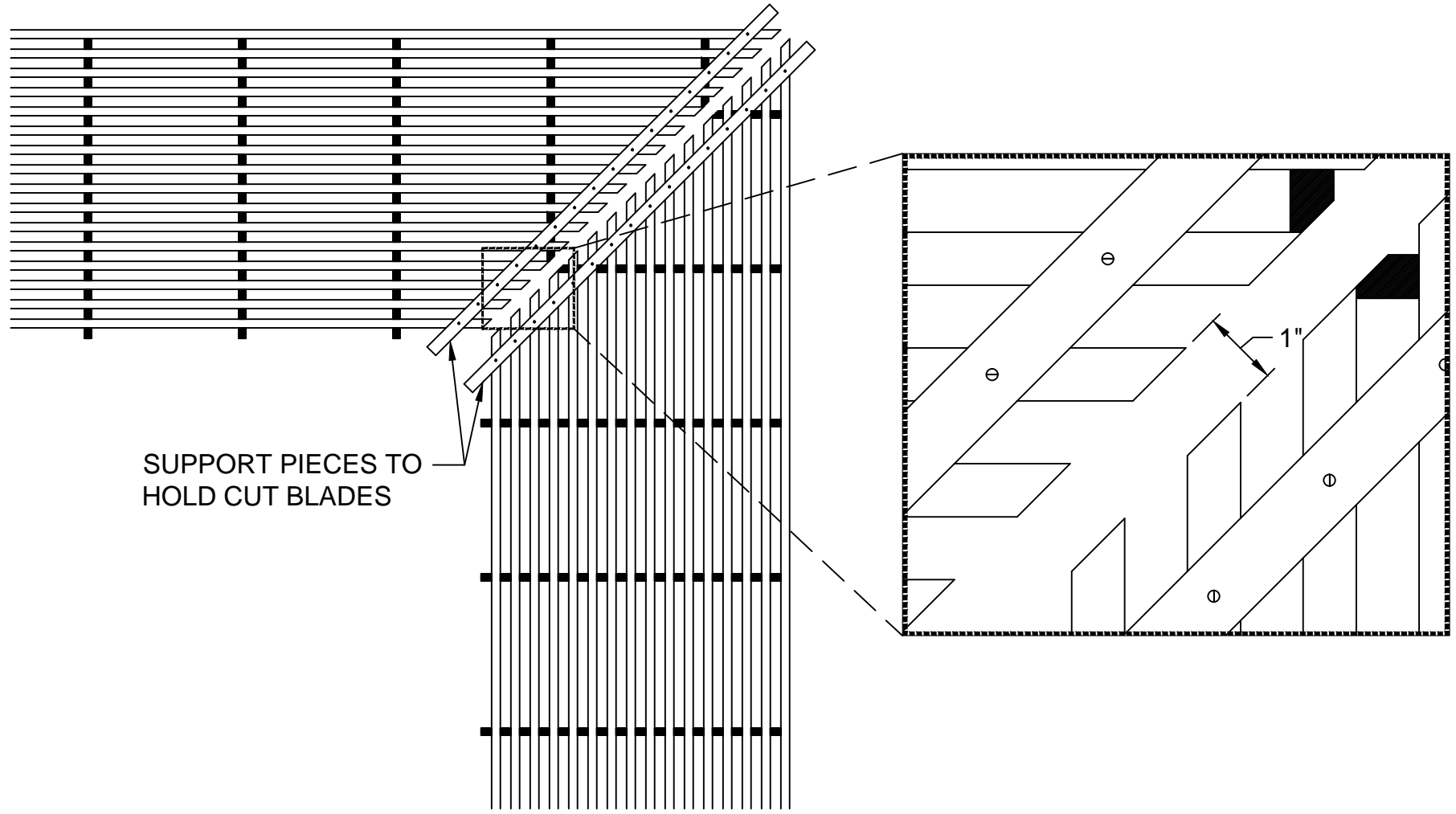

SUPPORT PIECES TO HOLD CUT BLADES



**RULON INTERNATIONAL**

World Commerce Center  
 2000 Ring Way Road  
 St. Augustine, FL 32092  
 Ph: 1-800-227-8566  
 904-584-1400  
 Fax: 904-584-1499  
 www.rulonco.com  
 info@rulonco.com

PROJECT:

TITLE: **Panel Grille Miter Joint Detail**

ISSUE DATE:

REVISION DATE:  
**MAY/11/2011**

DRAWN BY:  
**CAP**

CHECKED BY:  
**TA**

PROJECT NUMBER:

DRAWING NUMBER:  
**GDCXX016**

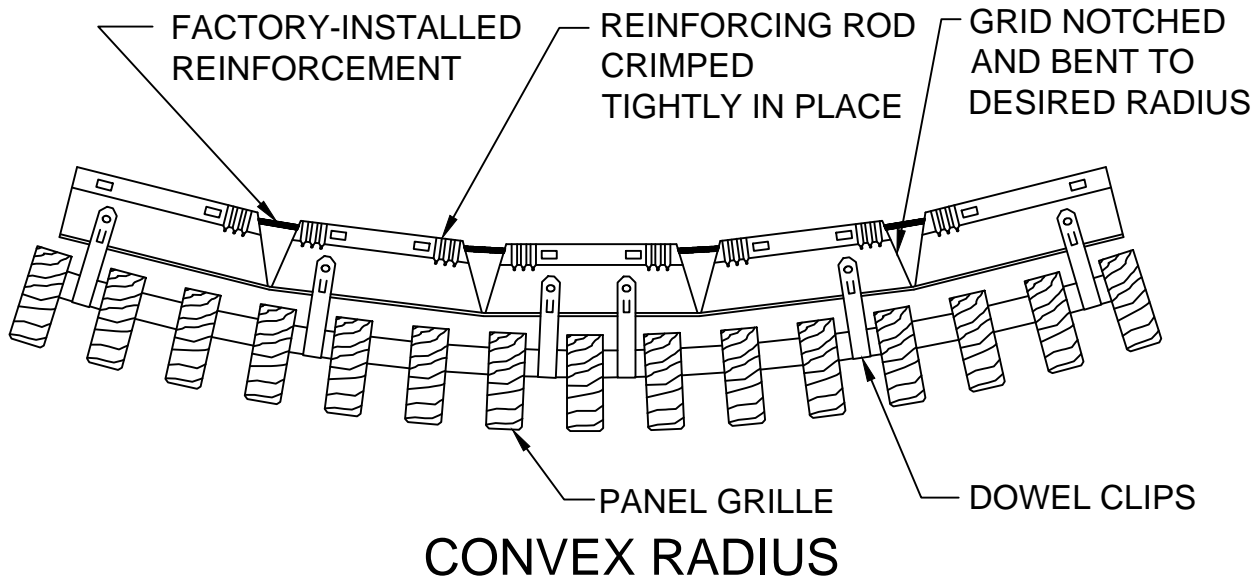
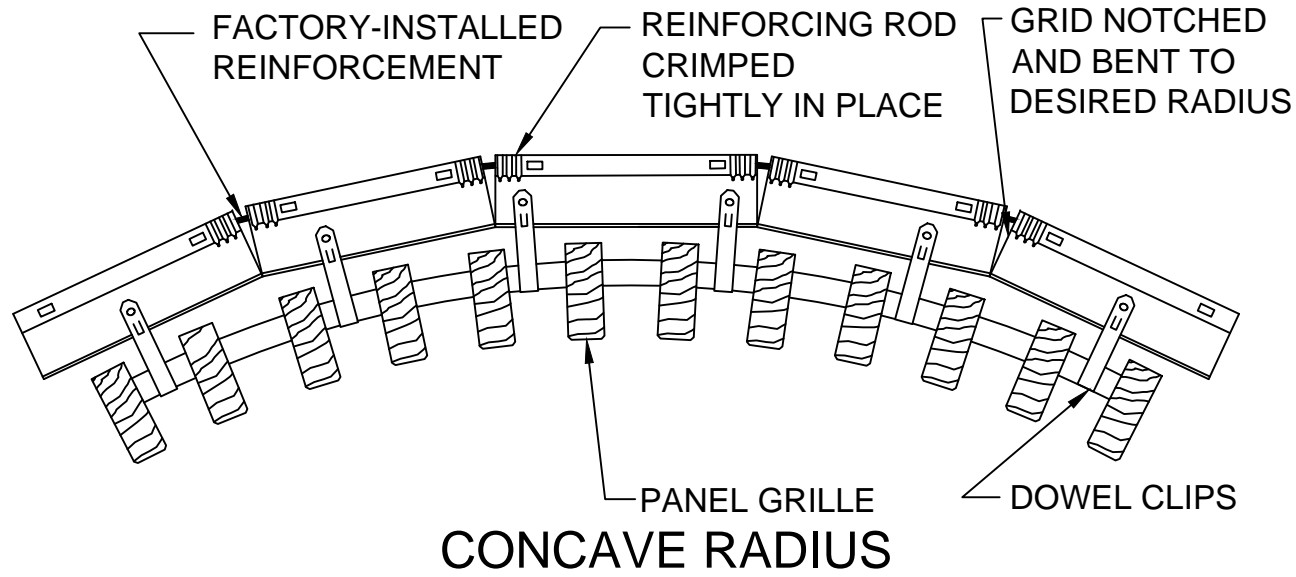

RULON INTERNATIONAL

World Commerce Center  
 2000 Ring Way Road  
 St. Augustine, FL 32092  
 Ph: 1-800-227-8566  
 904-584-1400  
 Fax: 904-584-1499  
 www.rulonco.com  
 info@rulonco.com

PROJECT:

TITLE:

Panel Grille - Flexible Doweled -  
 Grid Radius Detail

ISSUE DATE:

REVISION DATE:

MAY/11/2011

DRAWN BY:

CAP

CHECKED BY:

TA

PROJECT NUMBER:

DRAWING NUMBER:

GDCXX017

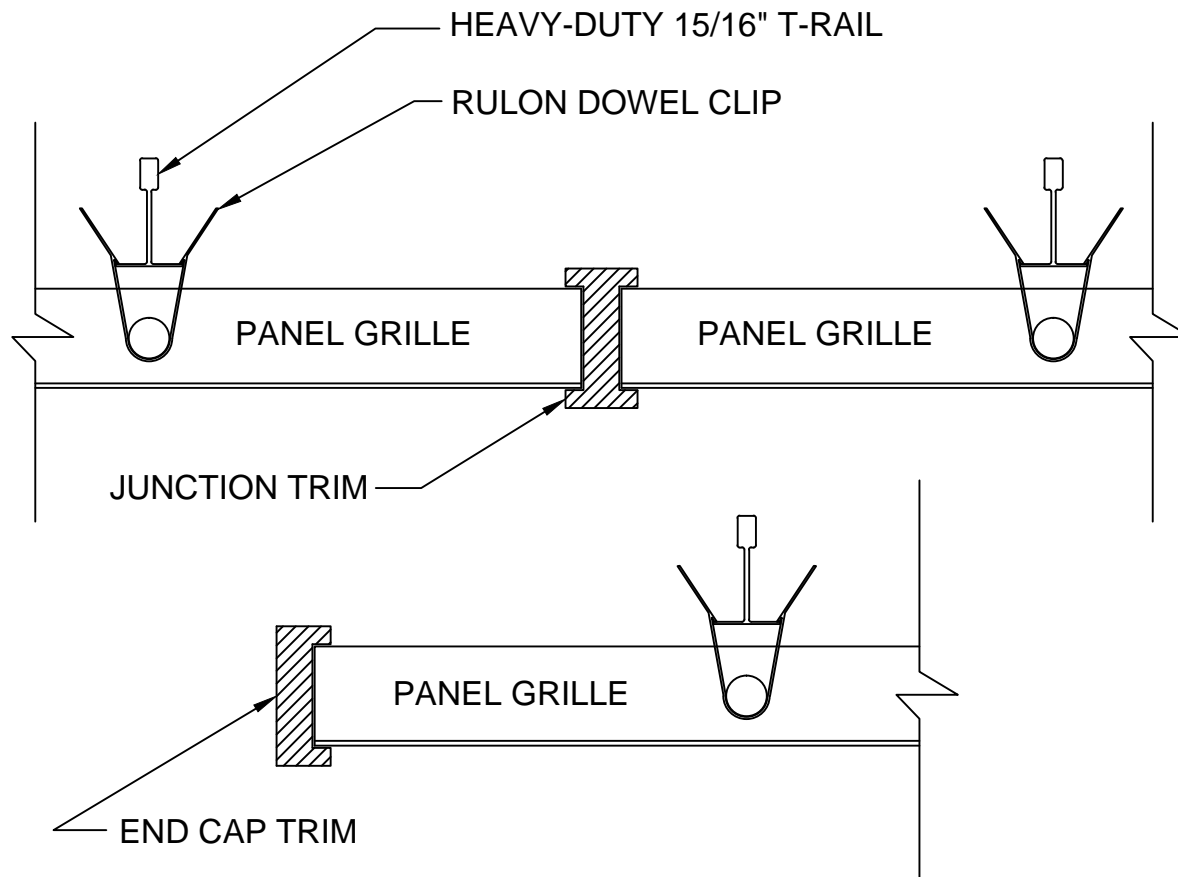

NOTE:  
 SIZE OF TRIMS VARIES WITH PANEL GRILLE PROFILE



**RULON INTERNATIONAL**

World Commerce Center  
 2000 Ring Way Road  
 St. Augustine, FL 32092  
 Ph: 1-800-227-8566  
 904-584-1400  
 Fax: 904-584-1499  
 www.rulonco.com  
 info@rulonco.com

PROJECT:

TITLE:

**Panel Grille - Doweled - End Cap  
 and Junction Trim Detail**

ISSUE DATE:

REVISION DATE:

**MAY/11/2011**

DRAWN BY:

**CAP**

CHECKED BY:

**TA**

PROJECT NUMBER:

DRAWING NUMBER:

**GDCXX018**

PANEL GRILLES ARE SECURED INTO PLACE WITH DOWEL CLIPS.

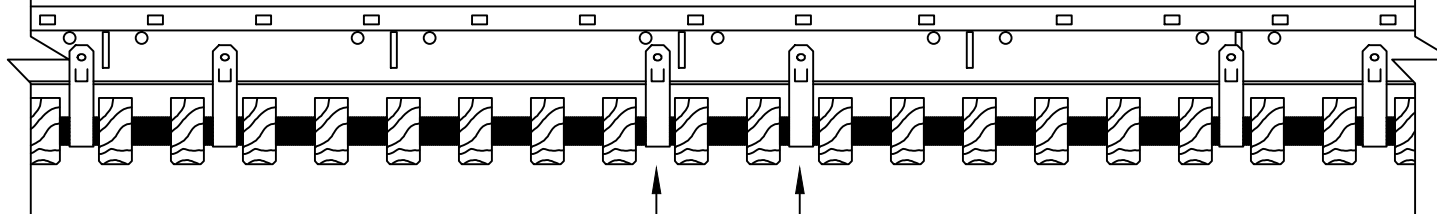

1. REMOVE ADJACENT DOWEL CLIPS AT DESIRED REMOVAL SITE.

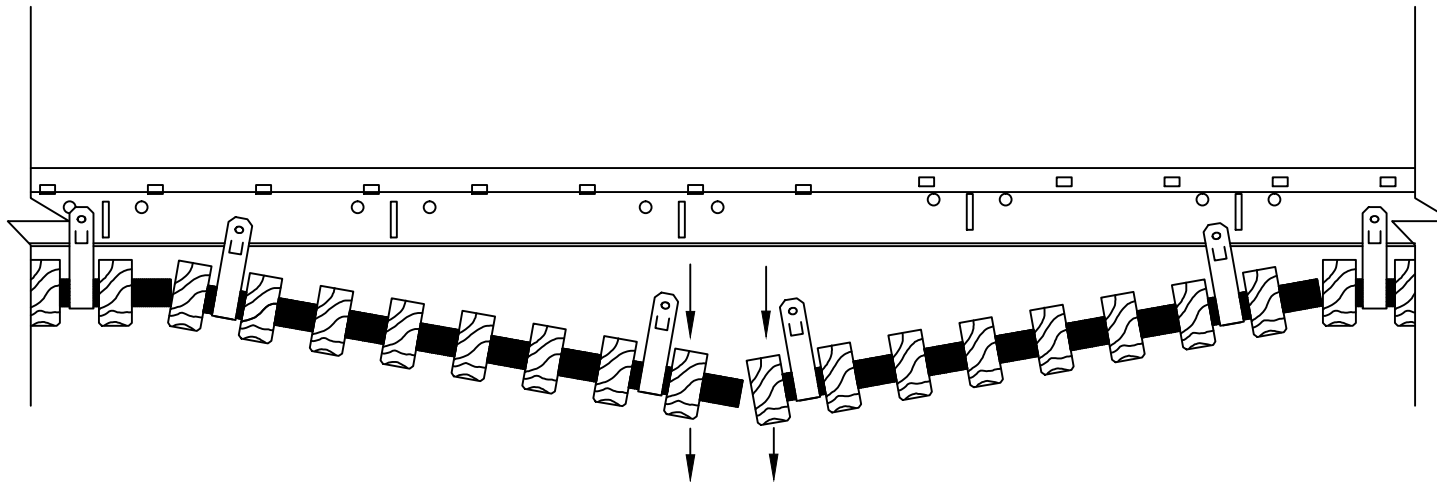

2. WITH SUFFICIENT DOWEL CLIPS RELEASED, PANEL MAY BE EASILY REMOVED.



RULON INTERNATIONAL

World Commerce Center  
2000 Ring Way Road  
St. Augustine, FL 32092  
Ph: 1-800-227-8566  
904-584-1400  
Fax: 904-584-1499  
www.rulonco.com  
info@rulonco.com

PROJECT:

TITLE:

Panel Grille - Doweled - Panel  
Removal Detail

ISSUE DATE:

REVISION DATE:

MAY/11/2011

DRAWN BY:

CAP

CHECKED BY:

TA

PROJECT NUMBER:

DRAWING NUMBER:

GDCXX019

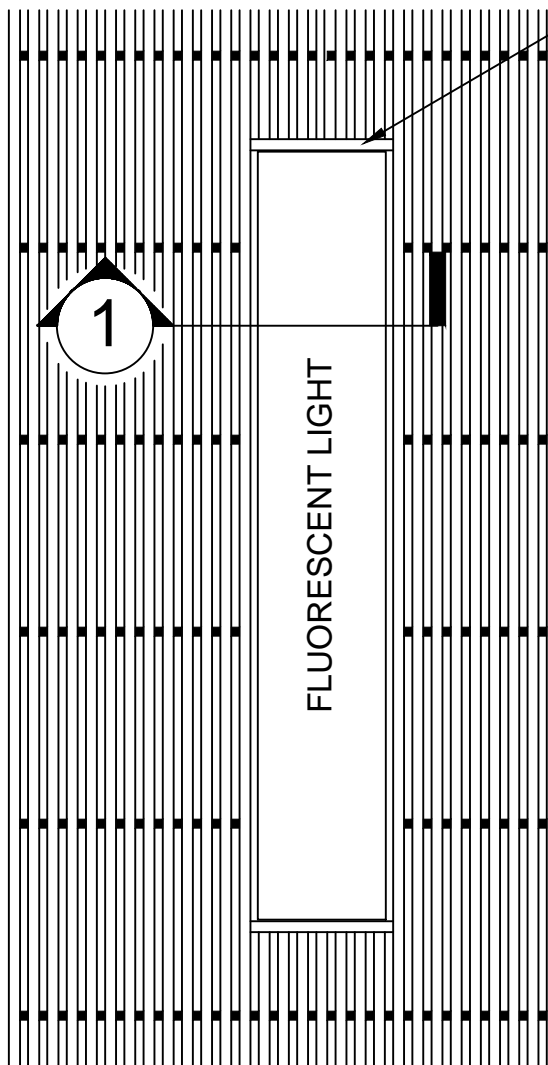

PLAN VIEW

USE CUT-OFF PIECES OF PANEL GRILLE BLADE AS TRIM PIECE. ATTACH AS NECESSARY

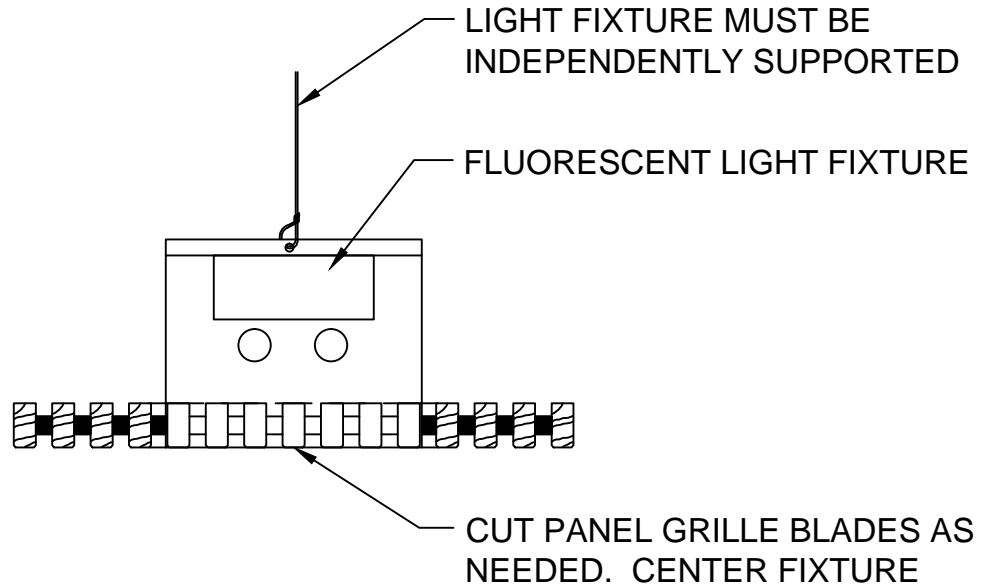

1 SECTION THROUGH WOOD STRIPS



RULON INTERNATIONAL

World Commerce Center  
 2000 Ring Way Road  
 St. Augustine, FL 32092  
 Ph: 1-800-227-8566  
 904-584-1400  
 Fax: 904-584-1499  
 www.rulonco.com  
 info@rulonco.com

PROJECT:  
  
 TITLE: **Panel Grille - Doweled - Strip Light Installation Detail**

ISSUE DATE:  
  
 REVISION DATE:  
**MAY/11/2011**

DRAWN BY:  
**CAP**  
  
 CHECKED BY:  
**TA**

PROJECT NUMBER:  
  
 DRAWING NUMBER:  
**GDCXX024**

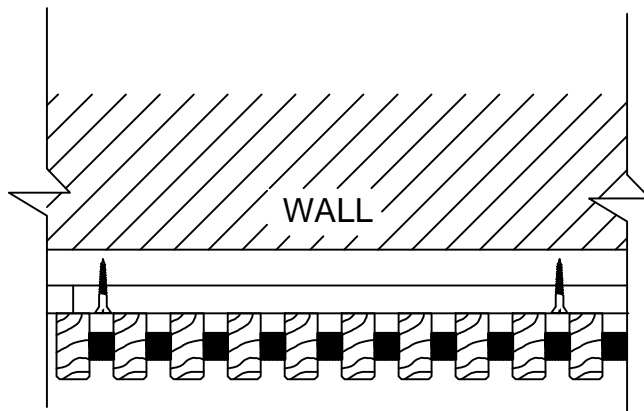

PLAN VIEW

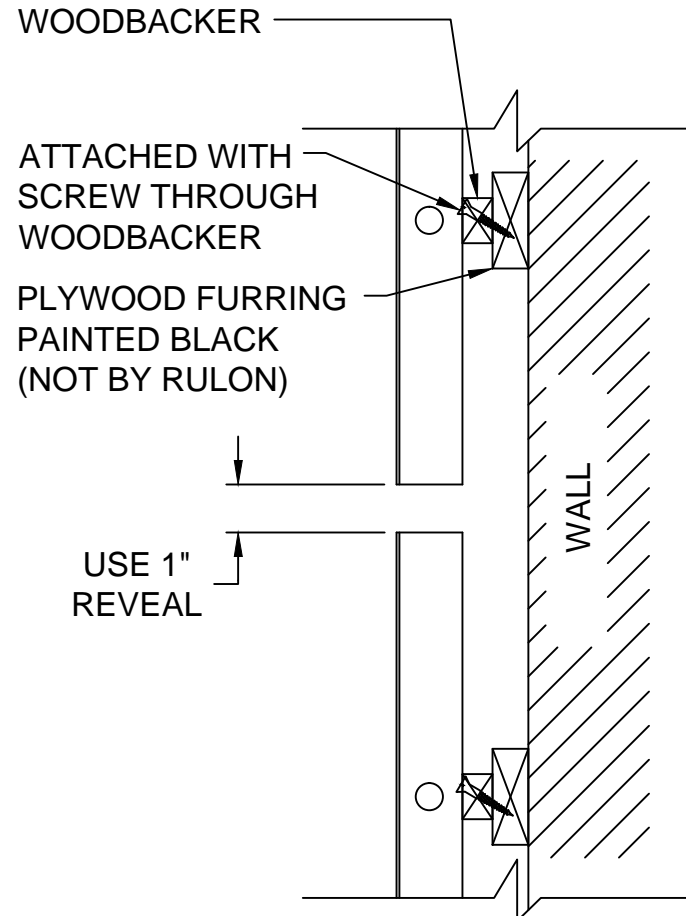

WALL SECTION



**RULON INTERNATIONAL**

World Commerce Center  
 2000 Ring Way Road  
 St. Augustine, FL 32092  
 Ph: 1-800-227-8566  
 904-584-1400  
 Fax: 904-584-1499  
 www.rulonco.com  
 info@rulonco.com

PROJECT:

TITLE: **Panel Grille - Doweled  
 Woodbacked - Wall Mount Detail**

ISSUE DATE:

REVISION DATE:  
**MAY/11/2011**

DRAWN BY:  
**CAP**

CHECKED BY:  
**TA**

PROJECT NUMBER:

DRAWING NUMBER:  
**GBWXX031**