

## **RULON PANELIZED LINEAR WOOD CEILING SYSTEM**

### **ARCHITECTURAL SPECIFICATIONS**

#### **PART 1 - GENERAL**

- A. The Panelized Linear Suspended Wood Ceiling Systems covered by this specification shall be the products of the Rulon International, World Commerce Center, 2000 Ring Way Road, St. Augustine, FL 32092. Phone: 800-227-8566, Fax: 904-584-1499.
- B. The General Conditions and the requirements of Division 1 of the specifications shall apply to all work hereunder.
- C. All work shall be performed in accordance with the manufacturer's instructions, and in a manner satisfactory to the owner's representative.

#### **1.01 SCOPE**

Rulon International shall furnish all Panelized Linear Wood Panels and suspension woodbacker clips (if specified) necessary to complete installation by the contractor, in accordance with plans and specifications. The standard heavy-duty 15/16" T-rail carriers shall be supplied by contractor.

#### **1.02 RELATED WORK NOT INCLUDED UNDER THIS SECTION**

Suspension systems and components for ceilings, other than manufacturer's Panelized Linear Suspended Wood Ceiling System, are not included.

#### **1.03 QUALITY ASSURANCE**

- A. **Installer Qualifications:** The installer must be a firm with a minimum of two (2) years of successful experience in installation of suspended wood ceilings of similar requirements to this project. The installer must be acceptable to the architect, manufacturer, and owner's representative.
- B. **Fire Performance Characteristics:** When specified as "Fire Resistant", wood ceiling boards shall conform to Class 1, or A flame spread rating, when tested according to ASTM E-84.
- C. **Environmental Standards:** When required the wood ceiling shall originate from well managed forests as certified by accredited and recognized industry certifying organizations.

#### **1.04 PROJECT CONDITIONS**

Installation shall be done only when the temperature and humidity closely approximate the interior conditions that will exist when the building is occupied. The heating and cooling systems shall be operating before, during, and after installation, with the humidity of the interior spaces maintained between 25% and 55%.

It is important that plenums have proper ventilation, especially in high moisture areas. There shall be no excessive build up of heat in the ceiling areas.

Prior to the start of installation, all exterior windows and doors are to be in place, glazed, and weather-stripped. The roof is to be watertight, and all wet trades' work is to be completed, and thoroughly dry.

Mechanical, electrical, and other utility service installations above the ceiling plane shall have been completed. No materials should rest against, or wrap around, the ceiling suspension components or connecting hangers.

#### **1.05 COORDINATION OF WORK**

The layout and installation of Panelized Linear Wood Panels and ceiling suspension system shall be coordinated with other work penetrating the ceiling. This includes light fixtures, HVAC equipment, and fire suppression system components.

#### **1.06 SUBMITTALS**

- A. Product Data: Rulon International shall provide product specifications and installation instructions for all supplied ceiling materials.
- B. Shop Drawings: When required, Rulon International shall supply shop drawings showing Panel lengths, and placement of hangers, T-rail carriers, and other details deemed pertinent to proper installation.
- C. Samples: A 12"x12" inch wood ceiling sample, in the specified Panelized Linear Wood Panel style, with finish applied, shall be submitted for approval.

#### **1.07 DELIVERY, STORAGE, AND HANDLING**

- A. Panelized Linear Wood Panels and components shall be delivered to the project site in original, unopened packages.
- B. The Panelized Linear Wood Panels shall be stored flat and level in a fully enclosed space. For a minimum of seventy-two (72) hours immediately prior to ceiling installation, the Panelized Linear Wood Panels shall be stored in the room in which they will be installed. The temperature and humidity of the room shall closely approximate those conditions that will exist when the building is occupied. The Panelized Linear Wood Panels must be stored off the floor.
- C. Care in handling must be exercised to avoid damage.

## 1.08 WARRANTIES

- A. Manufacturer: All materials supplied by the ceiling manufacturer shall be guaranteed against manufacturing defects for one (1) year. Because of differing site conditions, wood stains and colorings can vary with age, and are excluded from this warranty.
- B. Contractor: All work shall be guaranteed for one (1) year from final acceptance of completed work.

## PART 2 - PRODUCT

### 2.01 LINEAR WOOD PANELS

The wood strips shall be manufactured by Rulon International, St. Augustine, Florida, PH-1-800-227-8566. Linear Wood Strips shall be made from prime grade, all-natural [specie] [wood OR veneer on core board] with a [selected] finish.

Panelized Linear Wood Panels are assembled from boards using [specified] modules, having wood strips [X] inches thick x [X] inches wide with a [X] inch space between the boards. A fiberfelt spacer shall be factory-installed between the wood strips. The fiberfelt spacer is provided in a standard black color.

Panelized Linear Wood Panels shall be assembled [specified width] wide in [specified] lengths. Panels shall be fastened together with woodbackers, positioned 5 1/2" from the ends and 12" on center, with overlapping attachment to the next panel for support of the system. Woodbackers shall be painted black.

Woodbacker clips shall be used to suspend LinearWood Panels when removability of panels is necessary for access above the ceiling.

Wood is a natural product that will undergo changes with variations in the environment. Therefore, all dimension tolerances are  $\pm 1/8"$ .

### 2.02 SUSPENSION SYSTEMS

Linear Wood Panels shall be suspended from standard heavy-duty 15/16" T-rail carriers - using Rulon woodbacker clips for connection. #12-gauge wire hangers shall suspend T-rail carriers.

### 2.03 EDGES, BORDERS, AND PERIMETER TRIMS

Edges, borders, and perimeter trims, shall be designated by specifier in accordance with standard design details available. All wood ceiling products specified shall be supplied by the ceiling manufacturer.

## **2.04 FINISHES AND COLORS**

All Panelized Linear Wood Panels shall be factory-finished with clear sealers, wood stains, or semi-transparent color treatments as selected. All finishes shall be selected by the designer, architect, or designated owner's representative.

Wood is a natural product with variations in grain, texture, and color - often ranging from light to dark - thereby, affecting the surface look. Product finishes shall be stain or sealer coats, spray-applied to a smooth-sanded surface.

## **PART 3 - EXECUTION**

### **3.01 PREPARATION**

- A. Ceiling Layout: The contractor shall measure ceiling areas, and establish layout of Panelized Linear Wood Panels and T-rails, in accordance with installation instructions.
- B. Coordination: The contractor shall furnish the layout for supports that shall be installed for suspension of ceilings. He shall furnish concrete inserts, steel deck hanger clips, or similar devices for installation, in time to coordinate the work. The contractor shall coordinate with other trades the location of devices which will penetrate the Ceiling Panels or interfere with the installation. Recessed or surface devices located within the ceiling panels are to be located and cut in the field.

### **3.02 INSTALLATION**

- A. General: The contractor shall install materials in accordance with Rulon International printed instructions. The installation shall comply with applicable regulations and industry standards.
- B. Perimeters: Using a leveling device, the contractor shall lay out and install the perimeter trim as specified.
- C. Suspension: The T-rail carriers shall be suspended and leveled in a direction perpendicular to the wooden strip direction. #12-gauge wire hangers shall be used to support T-rail carriers. Hangers shall be placed at no more than 4' intervals along the carrier.
- D. Wood Suspension: Panelized Linear Wood Panels shall be suspended from the T-rail carrier system by woodbacker clips.

### **3.03 ADJUSTMENT, CLEANING, AND REPAIR**

- A. The contractor shall make final adjustments to level or contours.
- B. Upon completion of ceiling installation, all Panelized Linear Wood Panels and borders shall be cleaned free of dirt, dust, grease, oils, and fingerprints.

- C. All work which cannot be successfully cleaned or repaired shall be removed and replaced.

### **3.04 INSPECTION**

Upon completion of ceiling installation, the owner's representative shall inspect all finished surfaces to ensure that work has been performed in a manner satisfactory to the owner. Any deficiencies in the installed ceiling shall be corrected by the contractor at no additional cost to the owner, or to the ceiling manufacturer.

## **RULON PANELIZED LINEAR WOOD WALL SYSTEM**

### **ARCHITECTURAL SPECIFICATIONS**

#### **PART 1 - GENERAL**

- A. The Panelized Linear Suspended Wood Wall Systems covered by this specification shall be the products of the Rulon International, World Commerce Center, 2000 Ring Way Road, St. Augustine, FL 32092. Phone: 800-227-8566, Fax: 904-584-1499.
- B. The General Conditions and the requirements of Division 1 of the specifications shall apply to all work hereunder.
- C. All work shall be performed in accordance with the manufacturer's instructions, and in a manner satisfactory to the owner's representative.

#### **1.01 SCOPE**

Rulon International shall furnish all Panelized Linear Wood Panels necessary to complete installation by the contractor, in accordance with plans and specifications.

#### **1.02 RELATED WORK NOT INCLUDED UNDER THIS SECTION**

Attachment systems and components for walls, other than manufacturer's Panelized Linear Wood System, are not included.

#### **1.03 QUALITY ASSURANCE**

- A. **Installer Qualifications:** The installer must be a firm with a minimum of two (2) years of successful experience in installation of wood systems of similar requirements to this project. The installer must be acceptable to the architect, manufacturer, and owner's representative.
- B. **Fire Performance Characteristics:** When specified as "Fire Resistant", wood boards shall conform to Class 1, or A flame spread rating, when tested according to ASTM E-84.
- C. **Environmental Standards:** When required the wood shall originate from well managed forests as certified by accredited and recognized industry certifying organizations.

#### **1.04 PROJECT CONDITIONS**

Installation shall be done only when the temperature and humidity closely approximate the interior conditions that will exist when the building is occupied. The heating and cooling systems shall be operating before, during, and after installation; with the humidity of the interior spaces maintained between 25% and 55%.

It is important that plenums have proper ventilation, especially in high moisture areas. There shall be no excessive build up of heat in the wall areas.

Prior to the start of installation, all exterior windows and doors are to be in place, glazed, and weather-stripped. The roof is to be watertight, and all wet trades' work is to be completed, and thoroughly dry.

Mechanical, electrical, and other utility service installations beyond the wall plane shall have been completed. No materials should rest against, or wrap around, the wall attachment components.

#### **1.05 COORDINATION OF WORK**

The layout and installation of Panelized Linear Wood Panels shall be coordinated with other work penetrating the wall.

#### **1.06 SUBMITTALS**

- A. Product Data: Rulon International shall provide product specifications and installation instructions for all supplied wall materials.
- B. Shop Drawings: When required, Rulon International shall supply shop drawings showing Panel lengths and placement, and other details deemed pertinent to proper installation.
- C. Samples: A 12"x12" inch wood wall sample, in the specified Panelized Linear Wood Panel style, with finish applied, shall be submitted for approval.

#### **1.07 DELIVERY, STORAGE, AND HANDLING**

- A. Panelized Linear Wood Panels and components shall be delivered to the project site in original, unopened packages.
- B. The Panelized Linear Wood Panels shall be stored flat and level in a fully enclosed space. For a minimum of seventy-two (72) hours immediately prior to wall installation, the Panelized Linear Wood Panels shall be stored in the room in which they will be installed. The temperature and humidity of the room shall closely approximate those conditions that will exist when the building is occupied. The Panelized Linear Wood Panels must be stored off the floor.
- C. Care in handling must be exercised to avoid damage.

## 1.08 WARRANTIES

- A. Manufacturer: All materials supplied by the panel manufacturer shall be guaranteed against manufacturing defects for one (1) year. Because of differing site conditions, wood stains and colorings can vary with age, and are excluded from this warranty.
- B. Contractor: All work shall be guaranteed for one (1) year from final acceptance of completed work.

## PART 2 - PRODUCT

### 2.01 LINEAR WOOD PANELS

The wood strips shall be manufactured by Rulon International, St. Augustine, Florida, PH-1-800-227-8566. Linear Wood Strips shall be made from prime grade, all-natural [specie] [wood OR veneer on core board] with a [selected] finish.

Panelized Linear Wood Panels are assembled from boards using [specified] modules, having wood strips [X] inches thick x [X] inches wide with a [X] inch space between the boards. A fiberfelt spacer shall be factory-installed between the wood strips. The fiberfelt spacer is provided in a standard black color.

Panelized Linear Wood Panels shall be assembled [specified width] wide in [specified] lengths. Panels shall be fastened together with woodbackers, positioned 5 1/2" from the ends and 12" on center, with overlapping attachment to the next panel for support of the system. Woodbackers shall be painted black.

Wood is a natural product that will undergo changes with variations in the environment. Therefore, all dimension tolerances are  $\pm 1/8"$ .

### 2.02 SUSPENSION SYSTEMS

Linear Wood Panels shall be installed using 'Z' clips or direct screw method.

### 2.03 EDGES, BORDERS, AND PERIMETER TRIMS

Edges, borders, and perimeter trims, shall be designated by specifier in accordance with standard design details available. All wood wall products specified shall be supplied by the panel manufacturer.

### 2.04 FINISHES AND COLORS

All Panelized Linear Wood Panels shall be factory-finished with clear sealers, wood stains, or semi-transparent color treatments as selected. All finishes shall be selected by the designer, architect, or designated owner's representative.

Wood is a natural product with variations in grain, texture, and color - often ranging from light to dark - thereby, affecting the surface look. Product finishes shall be stain or sealer coats, spray-applied to a smooth-sanded surface.

### **PART 3 - EXECUTION**

#### **3.01 PREPARATION**

- A. Layout: The contractor shall measure wall areas, and establish layout of Panelized Linear Wood Panels and furring strips, in accordance with installation instructions.
- B. Coordination: The contractor shall furnish the layout for supports that shall be installed for attachment of the wall panels.

#### **3.02 INSTALLATION**

- A. General: The contractor shall install materials in accordance with Rulon International printed instructions. The installation shall comply with applicable regulations and industry standards.
- B. Attachment: Panelized Linear Wood Panels shall be installed to furring strips by using either direct screw or 'Z' clips.

#### **3.03 ADJUSTMENT, CLEANING, AND REPAIR**

- A. The contractor shall make final adjustments to level or contours.
- B. Upon completion of ceiling installation, all Panelized Linear Wood Panels and borders shall be cleaned free of dirt, dust, grease, oils, and fingerprints.
- C. All work which cannot be successfully cleaned or repaired shall be removed and replaced.

#### **3.04 INSPECTION**

Upon completion of installation, the owner's representative shall inspect all finished surfaces to ensure that work has been performed in a manner satisfactory to the owner. Any deficiencies in the installed wall shall be corrected by the contractor at no additional cost to the owner, or to the wall panel manufacturer.

<u>DRAWING #</u>	<u>TITLE</u>
LOPXF001	Panelized Linear - Standard 4½" Module
LOP6F002	Panelized Linear - Standard 6" Module
LOPXF003	Panelized Linear - Woodbacker Clip Attachment
LOPXF004	Panelized Linear - Direct Screw Attachment (From Above)
LOPXF005	Panelized Linear - Direct Screw Attachment (From Below)
LOPXF006	Panelized Linear - Typical Panel Construction
LOPXF007	Panelized Linear - Woodbacker Clip Placement Detail
LOPXF008	Panelized Linear Trimming Detail
LOPXF009	Panelized Linear - Clearances

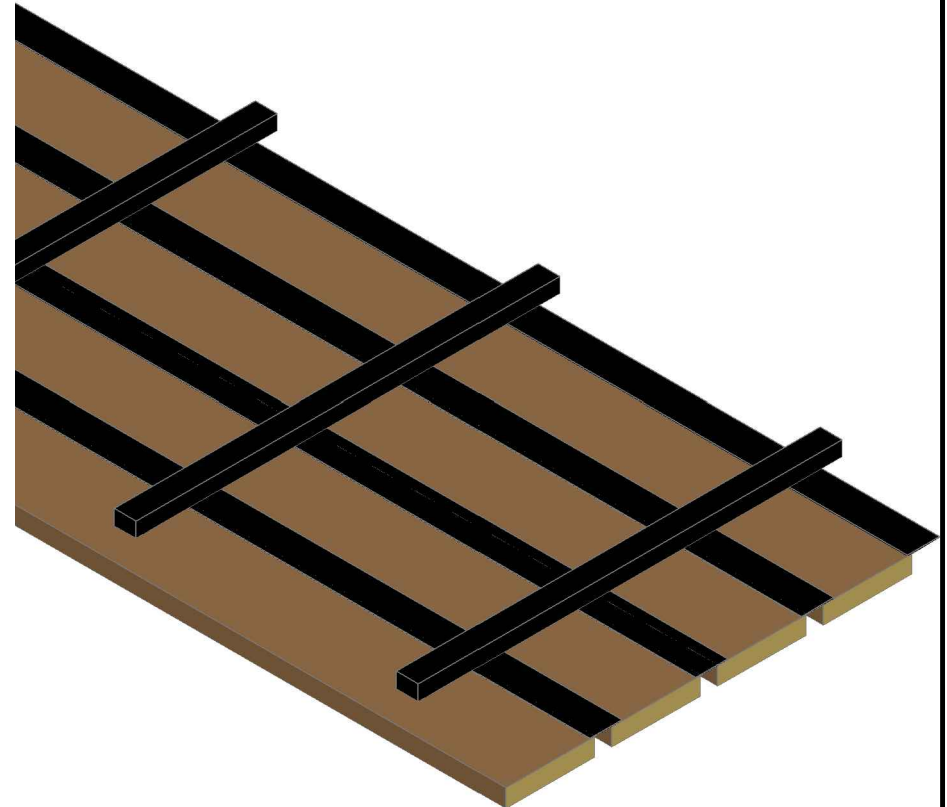

 <b>RULON INTERNATIONAL</b>	World Commerce Center 2000 Ring Way Road St. Augustine, FL 32092 Ph: 1-800-227-8566 904-584-1400 Fax: 904-584-1499 www.rulonco.com info@rulonco.com	PROJECT:  TITLE: <b>Panelized Linear Index</b>	ISSUE DATE:  REVISION DATE: <b>MAY/13/2011</b>	DRAWN BY: <b>CAP</b>  CHECKED BY: <b>TA</b>	PROJECT NUMBER:  DRAWING NUMBER: <b>LOPINDEX</b>

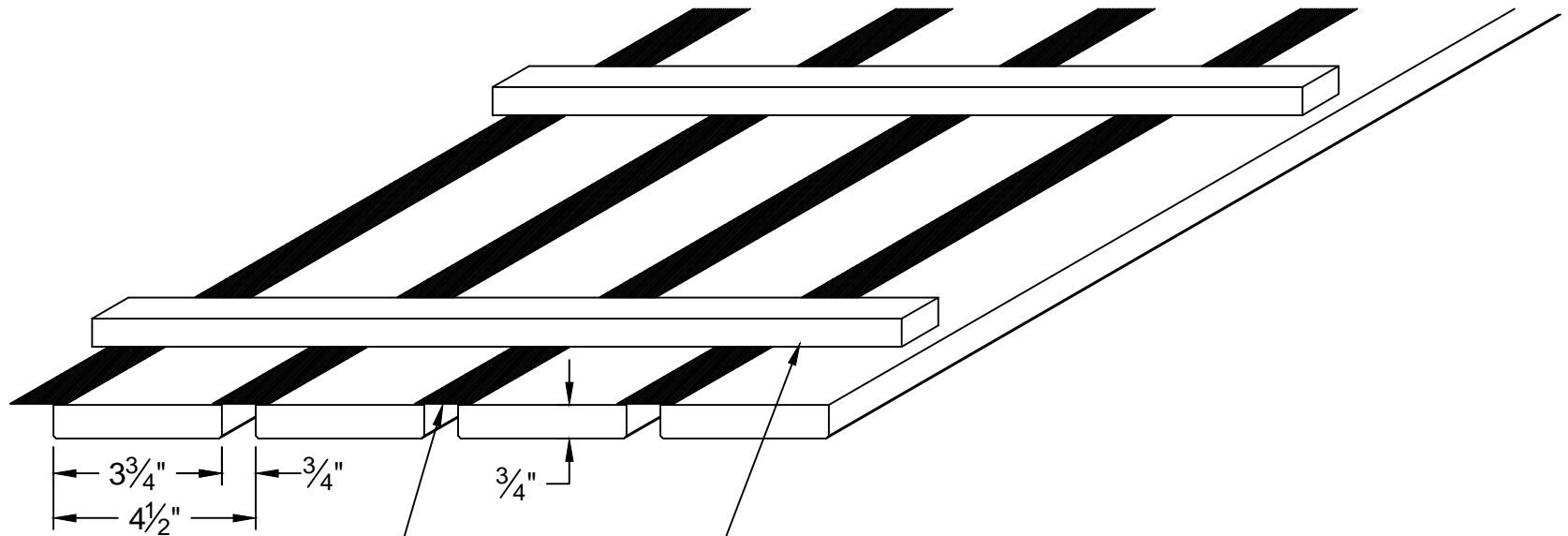

BLACK FIBERFELT  
SPACER

WOODBACKER

**NOTE:**

PANELIZED LINEAR MAY BE VENEERED OR SOLID WOOD CONSTRUCTION BASED ON PROJECT REQUIREMENTS. BOARD WIDTH, LENGTH (UP TO 10'), AND SPACING MAY VARY PER ARCHITECT'S DESIGN.



**RULON INTERNATIONAL**

World Commerce Center  
2000 Ring Way Road  
St. Augustine, FL 32092  
Ph: 1-800-227-8566  
904-584-1400  
Fax: 904-584-1499  
www.rulonco.com  
info@rulonco.com

PROJECT:

TITLE:

Panelized Linear - Standard 4 1/2" Module

ISSUE DATE:

MAY/11/2011

DRAWN BY:

CAP

CHECKED BY:

TA

PROJECT NUMBER:

DRAWING NUMBER:

LOPXF001

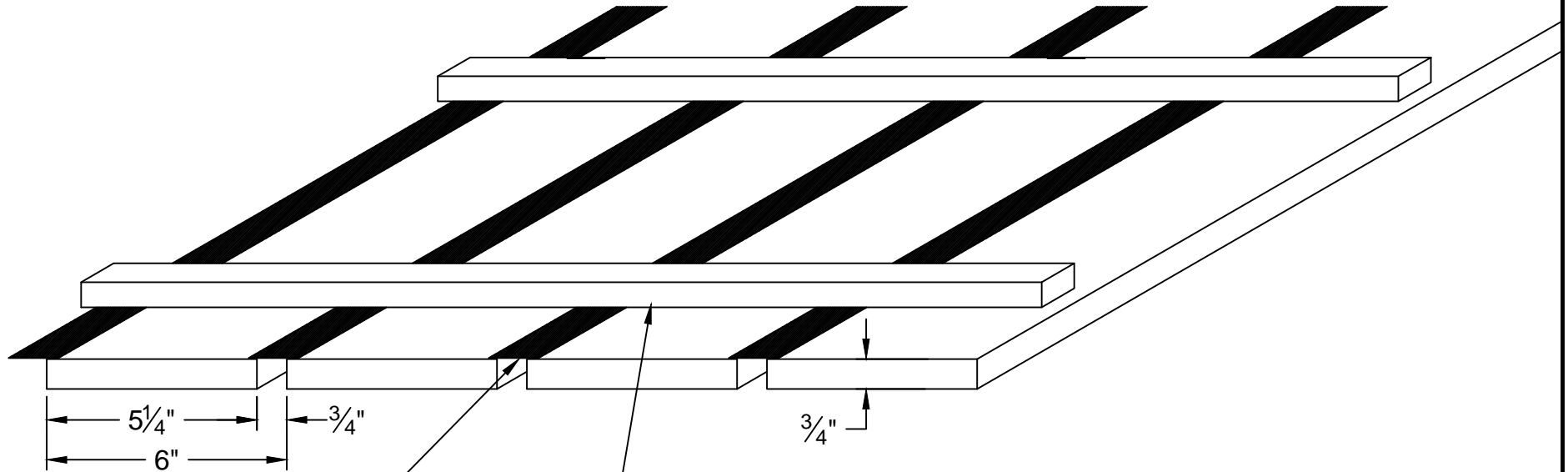

BLACK FIBERFELT SPACER —  
WOODBACKER —

NOTE:  
 PANELIZED LINEAR MAY BE VENEERED OR SOLID  
 WOOD CONSTRUCTION BASED ON PROJECT  
 REQUIREMENTS. BOARD WIDTH, LENGTH (UP TO 10'),  
 AND SPACING MAY VARY PER ARCHITECT'S DESIGN.



RULON INTERNATIONAL

World Commerce Center  
 2000 Ring Way Road  
 St. Augustine, FL 32092  
 Ph: 1-800-227-8566  
 904-584-1400  
 Fax: 904-584-1499  
 www.rulonco.com  
 info@rulonco.com

PROJECT:

TITLE:

Panelized Linear - Standard 6"  
 Module

ISSUE DATE:

MAY/11/2011

DRAWN BY:

CAP

CHECKED BY:

TA

PROJECT NUMBER:

DRAWING NUMBER:

LOP6F002

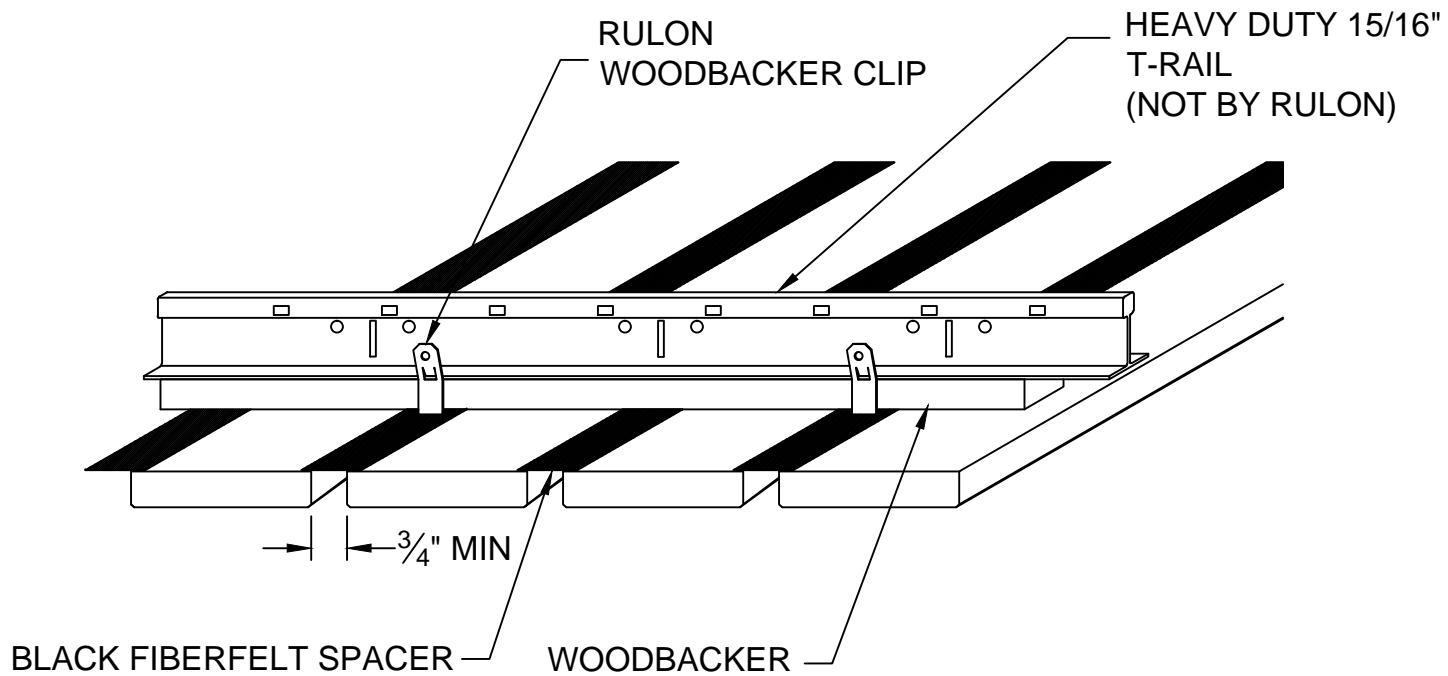

RULON INTERNATIONAL

World Commerce Center  
 2000 Ring Way Road  
 St. Augustine, FL 32092  
 Ph: 1-800-227-8566  
 904-584-1400  
 Fax: 904-584-1499  
 www.rulonco.com  
 info@rulonco.com

PROJECT:

TITLE:

Panelized Linear - Woodbacker  
 Clip Attachment

ISSUE DATE:

MAY/11/2011

DRAWN BY:

CAP

CHECKED BY:

TA

PROJECT NUMBER:

DRAWING NUMBER:

LOPXF003

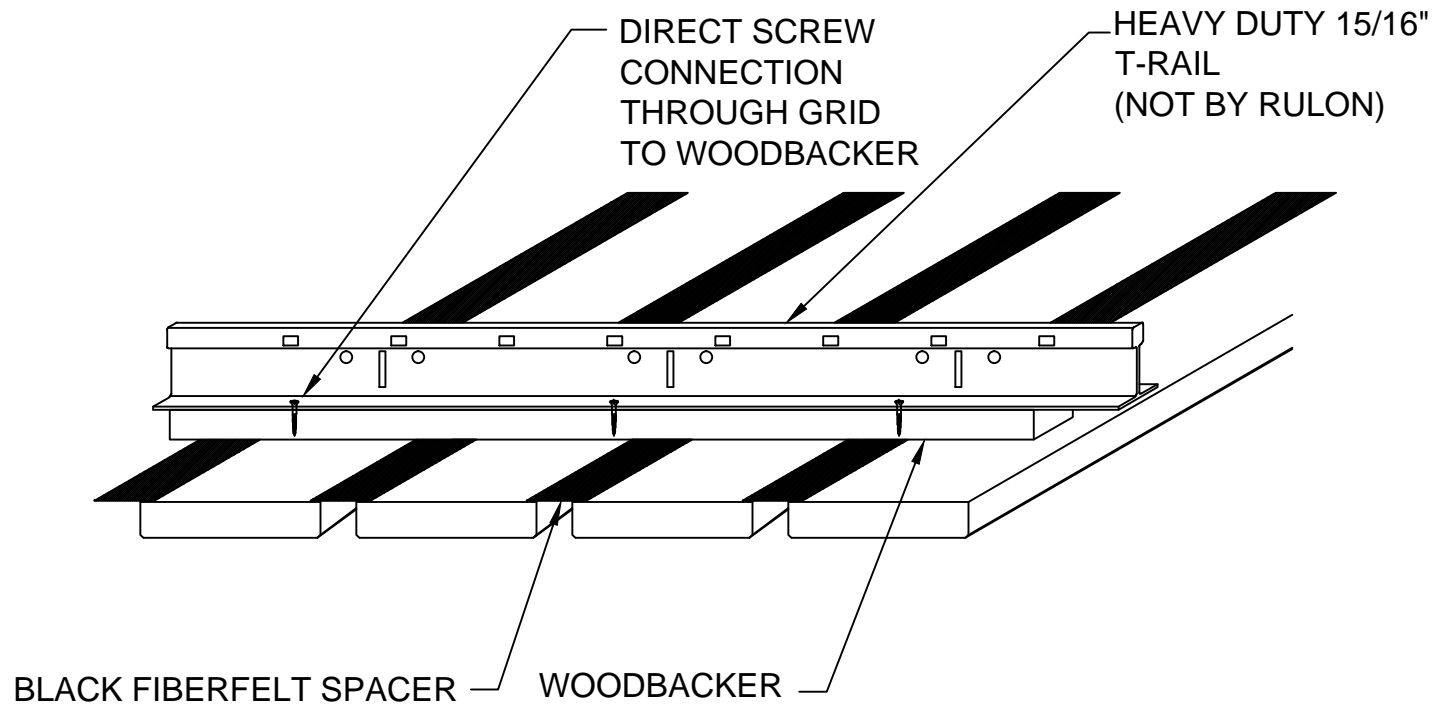

RULON INTERNATIONAL

World Commerce Center  
 2000 Ring Way Road  
 St. Augustine, FL 32092  
 Ph: 1-800-227-8566  
 904-584-1400  
 Fax: 904-584-1499  
 www.rulonco.com  
 info@rulonco.com

PROJECT:

TITLE:

Panelized Linear - Direct Screw Attachment (From Above)

ISSUE DATE:

MAY/11/2011

DRAWN BY:

CAP

CHECKED BY:

TA

PROJECT NUMBER:

DRAWING NUMBER:

LOPXF004

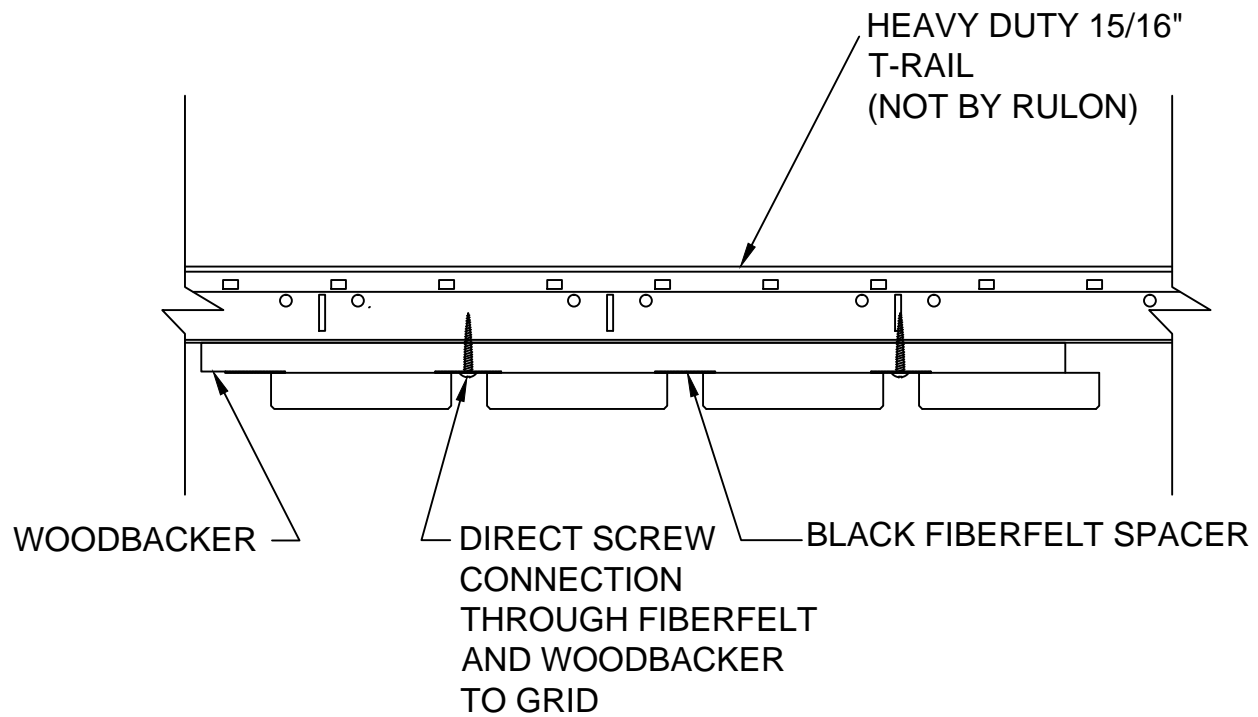

**RULON INTERNATIONAL**

World Commerce Center  
2000 Ring Way Road  
St. Augustine, FL 32092  
Ph: 1-800-227-8566  
904-584-1400  
Fax: 904-584-1499  
www.rulonco.com  
info@rulonco.com

PROJECT:

TITLE:

**Panelized Linear - Direct Screw  
Attachment (From Below)**

ISSUE DATE:

REVISION DATE:

**MAY/11/2011**

DRAWN BY:

**CAP**

CHECKED BY:

**TA**

PROJECT NUMBER:

DRAWING NUMBER:

**LOPXF005**

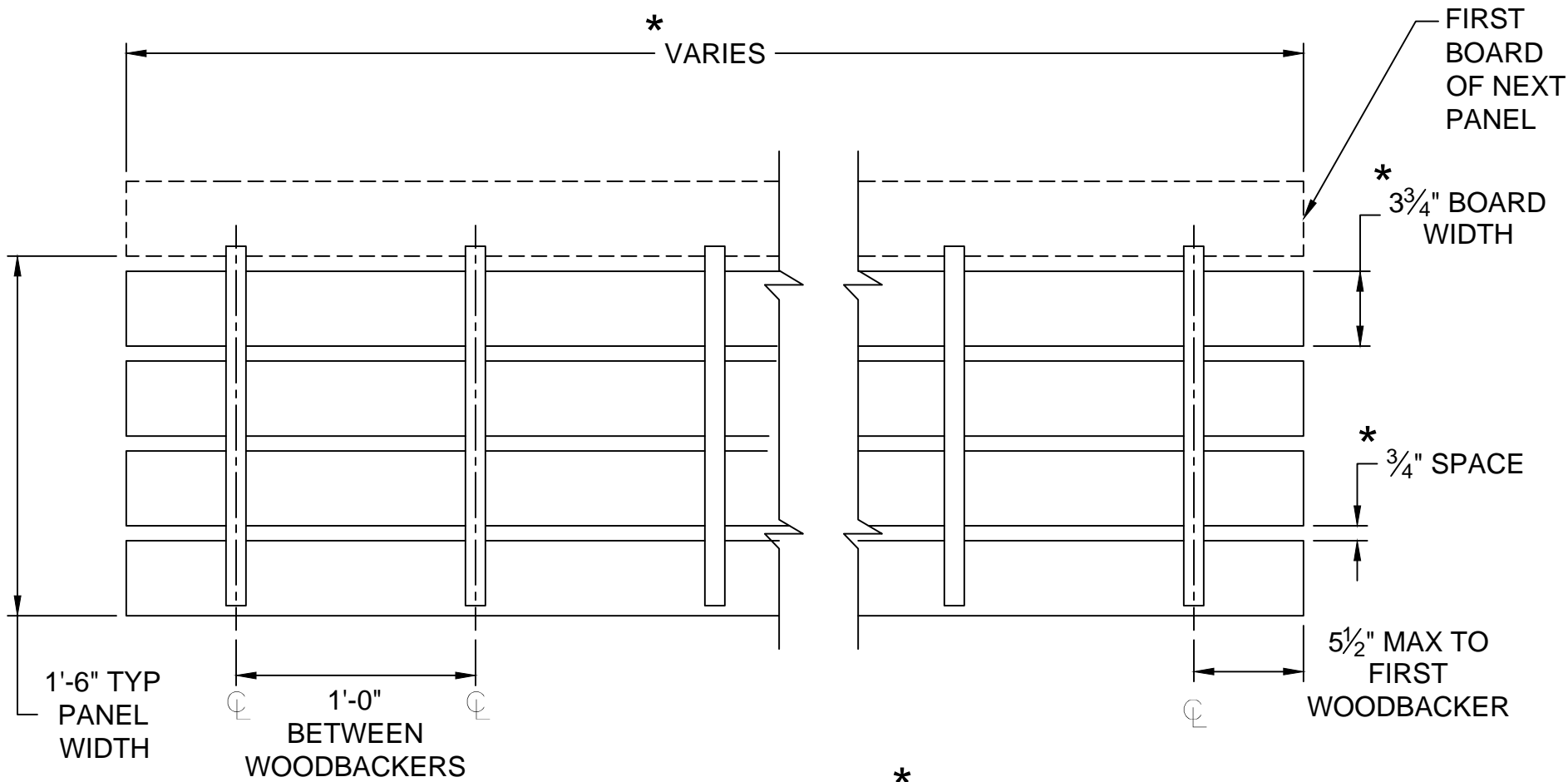

\* MAY VARY PER ARCHITECT'S DESIGN



RULON INTERNATIONAL

World Commerce Center  
 2000 Ring Way Road  
 St. Augustine, FL 32092  
 Ph: 1-800-227-8566  
 904-584-1400  
 Fax: 904-584-1499  
 www.rulonco.com  
 info@rulonco.com

PROJECT:

TITLE:

Panelized Linear - Typical Panel  
 Construction

ISSUE DATE:

MAY/11/2011

DRAWN BY:

CAP

CHECKED BY:

TA

PROJECT NUMBER:

DRAWING NUMBER:

LOPXF006

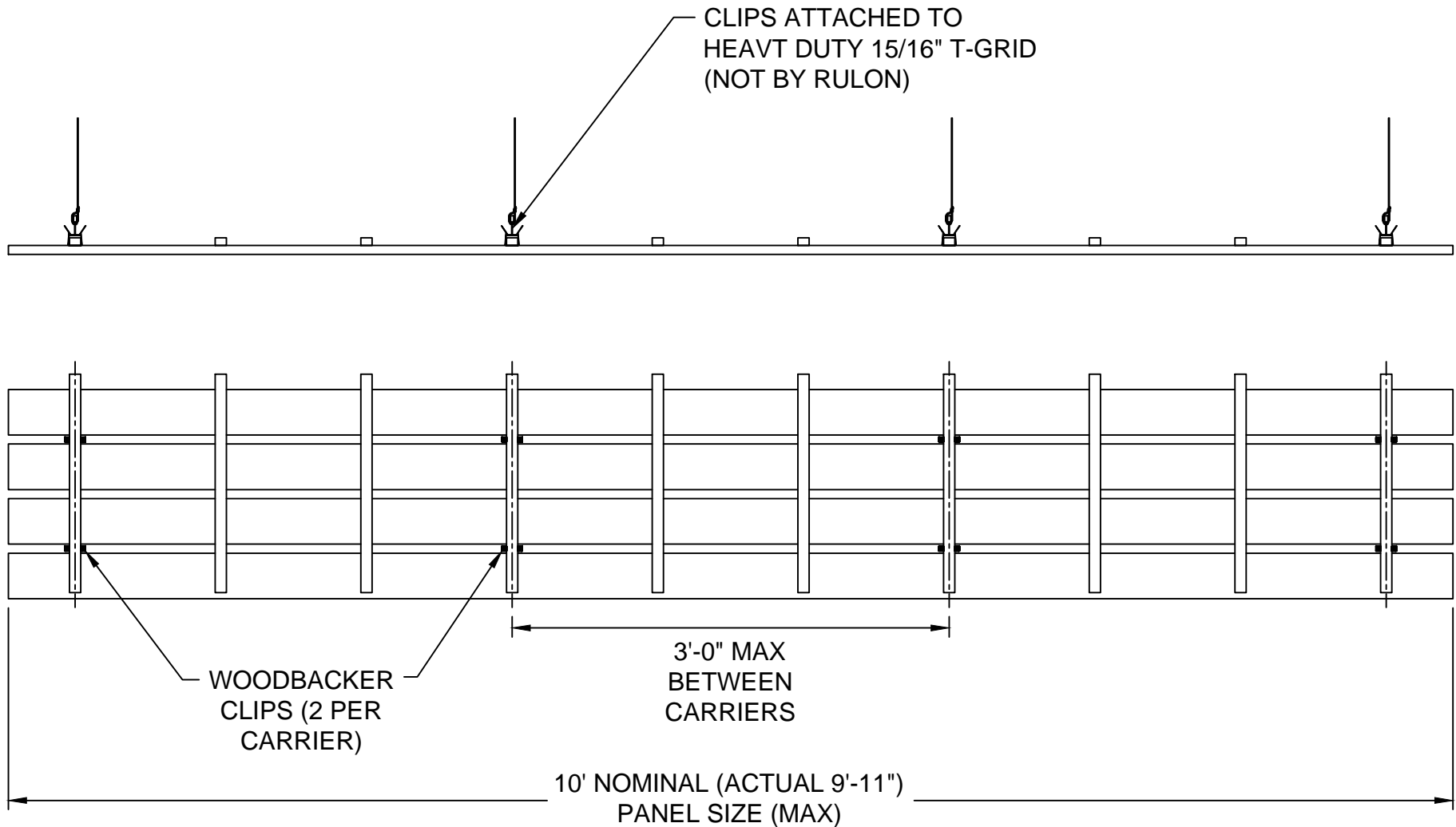

RULON INTERNATIONAL

World Commerce Center  
 2000 Ring Way Road  
 St. Augustine, FL 32092  
 Ph: 1-800-227-8566  
 904-584-1400  
 Fax: 904-584-1499  
 www.rulonco.com  
 info@rulonco.com

PROJECT:

TITLE:

Panelized Linear - Woodbacker Clip  
 Placement Detail

ISSUE DATE:

REVISION DATE:

MAY/11/2011

DRAWN BY:

CAP

CHECKED BY:

TA

PROJECT NUMBER:

DRAWING NUMBER:

LOPXF007

ATTACH WOOD STRIP OR  
SHORT PIECE OF T-RAIL  
TO BACK OF PANEL WITH  
WOOD SCREWS BEFORE  
CUTTING.

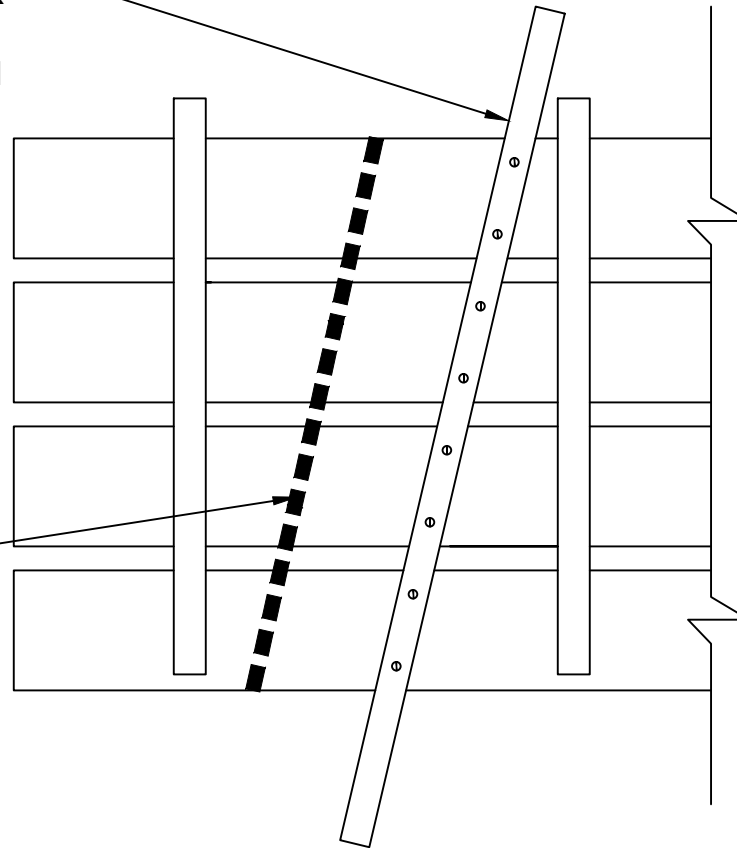

TRIM LINE -  
TOUCH-UP ALL  
FIELD-CUT ENDS  
WITH SUPPLIED  
TOUCH-UP FINISH

NOTE:  
WHEN CUTTING PANELS, BOARDS SHOULD  
NOT EXTEND BEYOND 6" UNSUPPORTED



**RULON INTERNATIONAL**

World Commerce Center  
2000 Ring Way Road  
St. Augustine, FL 32092  
Ph: 1-800-227-8566  
904-584-1400  
Fax: 904-584-1499  
www.rulonco.com  
info@rulonco.com

PROJECT:

TITLE:

**Panelized Linear Trimming Detail**

ISSUE DATE:

**MAY/11/2011**

DRAWN BY:

**CAP**

CHECKED BY:

**TA**

PROJECT NUMBER:

DRAWING NUMBER:

**LOPXF008**

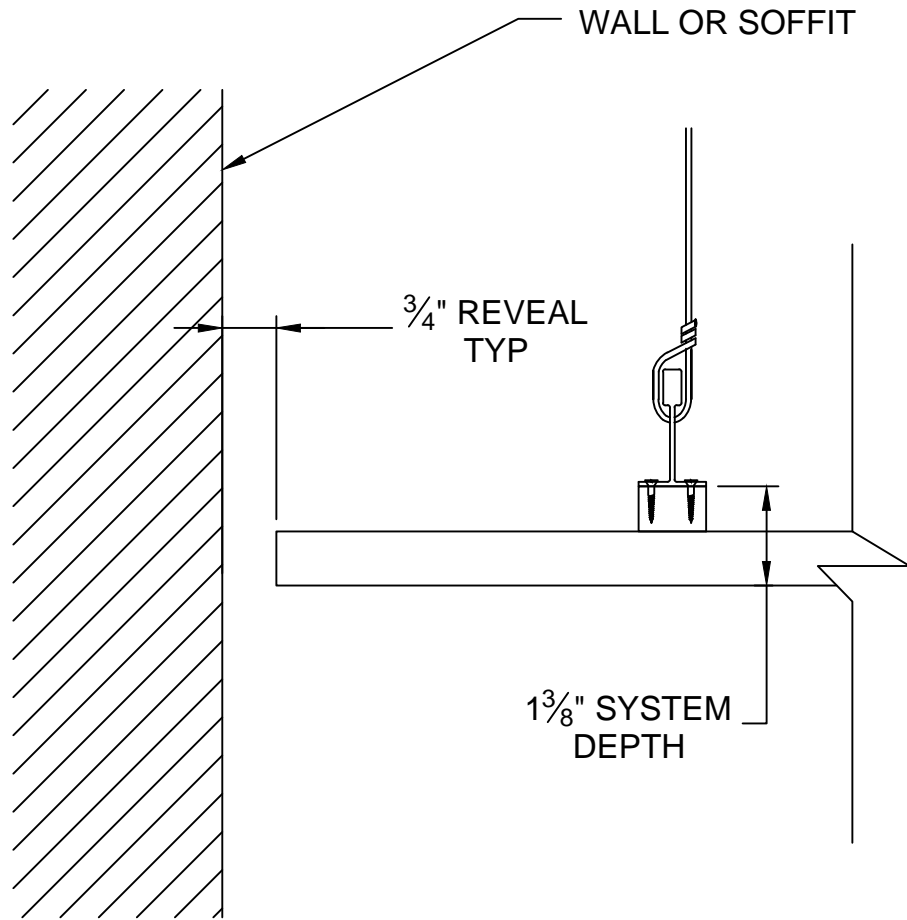

**OPTION A:**  
**DIRECTSCEW ATTACH**

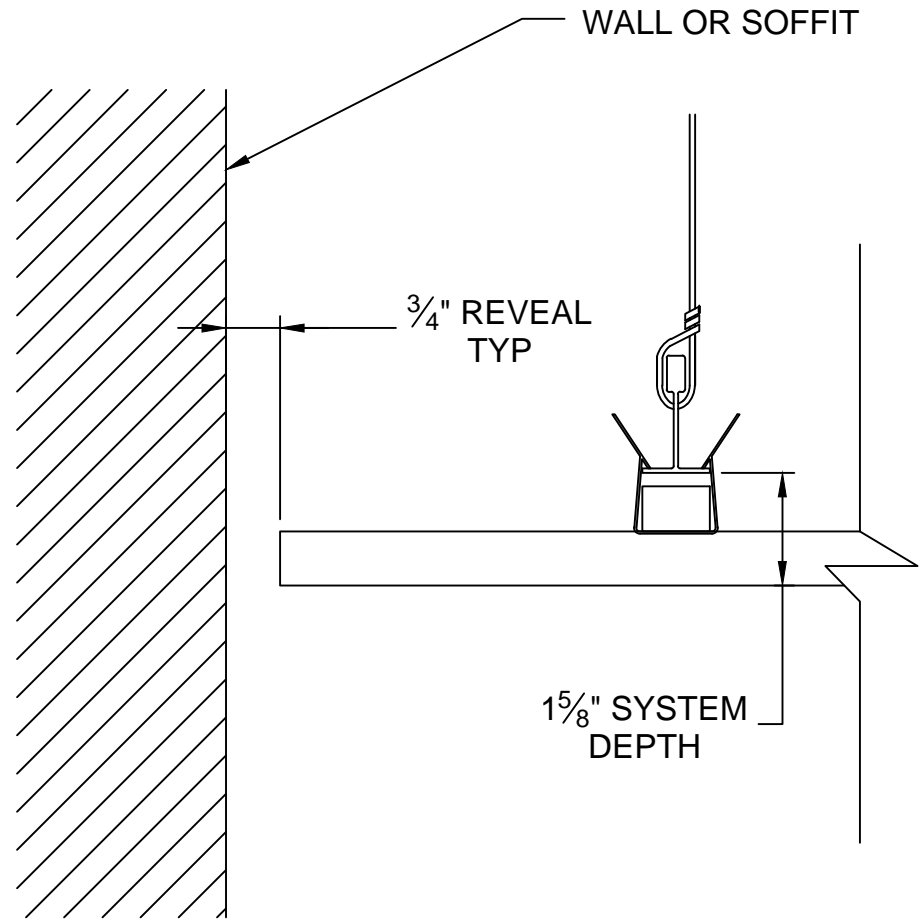

**OPTION B:**  
**WOODBACKEER CLIP**



**RULON INTERNATIONAL**

World Commerce Center  
 2000 Ring Way Road  
 St. Augustine, FL 32092  
 Ph: 1-800-227-8566  
 904-584-1400  
 Fax: 904-584-1499  
 www.rulonco.com  
 info@rulonco.com

PROJECT:

TITLE:

**Panelized Linear - Clearances**

ISSUE DATE:

**MAY/11/2011**

DRAWN BY:

**CAP**

CHECKED BY:

**TA**

PROJECT NUMBER:

DRAWING NUMBER:

**LOPXF009**